

Panasonic®

Operating Instructions

Home Network System Keychain Remote

Model No. **KX-HNK102**



Thank you for purchasing a Panasonic product.

This document explains how to operate the keychain remote properly. For details about how to use the system, refer to the User's Guide (page 12).

Please read this document before using the unit and save it for future reference.

For assistance, please contact us at 1-800-272-7033 or visit our Web site: <http://shop.panasonic.com/support> for customers in the U.S.A.

Please register your product: <http://shop.panasonic.com/support>

In order to use this device:

- Download the latest version of the **[Home Network]** app.
- Update your hub to the latest firmware version (version 5.50 or later).
For more information, refer to the User's Guide (page 12).

Printed in China

Table of Contents

Important Information

Accessory information	3
About this system	4
For your safety	4
Important safety instructions	5
For best performance	5
Other information	6

Setup

Part names and functions	8
LED indicator	8
Setup overview	9
Inserting the battery	10
Attaching the key ring	10
Registering the remote	11
Wireless communication range	11

Appendix

Using the remote	12
Features available when using the [Home Network] app	12
Accessing the User's Guide	12
Specifications	13
FCC and other information	14
Customer services	15
Limited Warranty (ONLY FOR U.S.A.)	16

Important Information

Accessory information

Supplied accessories

No.	Accessory item/Part number	Quantity
①	Battery*1	1
②	Key ring/PNGX1035Z	1

*1 When replacing the battery, refer to the battery specifications noted under "Power source" on page 13.

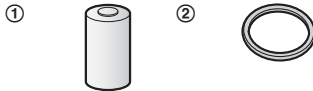

Other information

- Design and specifications are subject to change without notice.
- The illustrations in these instructions may vary slightly from the actual product.

Trademarks

- iPhone and iPad are registered trademarks of Apple Inc.
- Android is a trademark of Google Inc.
- Microsoft, Windows, and Internet Explorer are either registered trademarks or trademarks of Microsoft Corporation in the United States and/or other countries.
- All other trademarks identified herein are the property of their respective owners.

For assistance, please visit <http://shop.panasonic.com/support> 3

Important Information

About this system

- This system is an auxiliary system; it is not designed to provide complete protection from property loss. Panasonic will not be held responsible in the event that property loss occurs while this system is in operation.
- The system's wireless features are subject to interference, therefore functionality in all situations cannot be guaranteed. Panasonic will not be held responsible for injury or damage to property that occurs in the event of wireless communication error or failure.

For your safety

To prevent severe injury and loss of life/property, read this section carefully before using the product to ensure proper and safe operation of your product.

WARNING

Power connection

- Use only the power source marked on the product.
- Do not connect non-specified devices.

Installation

- To prevent the risk of fire or electrical shock, do not expose the product to rain or any type of moisture.
- Do not place or use this product near automatically controlled

devices such as automatic doors and fire alarms. Radio waves emitted from this product may cause such devices to malfunction resulting in an accident.

Operating safeguards

- Do not disassemble the product.

Medical

- Consult the manufacturer of any personal medical devices, such as pacemakers or hearing aids, to determine if they are adequately shielded from external RF (radio frequency) energy. DECT features operate between 1.92 GHz and 1.93 GHz with a peak transmission power of 115 mW.
- Do not use the product in health care facilities if any regulations posted in the area instruct you not to do so. Hospitals or health care facilities may be using equipment that could be sensitive to external RF energy.

CR Lithium battery

- Do not recharge, disassemble, remodel, heat or throw it into fire.
- Do not touch the terminals \oplus and \ominus with metal objects.
- Risk of explosion if battery is replaced by an incorrect type. Dispose of used battery according to local regulations.
- If any electrolyte should come into contact with your hands or clothes, wash it off thoroughly with water.
- If any electrolyte should come into contact with your eyes, never rub your eyes. Rinse your eyes

4 For assistance, please visit <http://shop.panasonic.com/support>

Important Information

thoroughly with water, and then consult a doctor.

CAUTION

CR Lithium battery

- Use only the battery noted on page 3.
- Insert the battery correctly.
- Do not leave the battery in an automobile exposed to direct sunlight for a long period of time with the doors and windows closed.
- Remove the battery if you do not use the product for a long period of time. Keep it in a cool, dark area.
- Do not replace a battery with wet hands.
- Keep out of the reach of small children. There is a risk of swallowing. If the battery is swallowed, seek medical attention immediately.
- Remove the battery if it becomes unusable. There is a risk of leakage, overheating, and rupture. Do not attempt to use a battery if it is leaking.
- Exercise care when handling the batteries. Do not allow conductive materials such as rings, bracelets, or keys to touch the batteries, otherwise a short circuit may cause the batteries and/or the conductive material to overheat and cause burns.
Do not intentionally pour water on the battery or allow it to get wet. There is a risk of fire and smoke. If the battery becomes wet, remove it immediately and contact an authorized service center.

Important safety instructions

When using your product, basic safety precautions should always be followed to reduce the risk of fire, electric shock, and injury to persons, including the following:

1. Do not use this product near water for example, near a bathtub, washbowl, kitchen sink, or laundry tub, in a wet basement or near a swimming pool.
2. Use only the batteries indicated in this document. Do not dispose of batteries in a fire. They may explode. Check with local codes for possible special disposal instructions.

SAVE THESE INSTRUCTIONS

For best performance

Hub location/avoiding noise

The hub and other compatible Panasonic devices use radio waves to communicate with each other.

- For maximum coverage and noise-free communications, place your hub:
 - at a convenient, high, and central location with no obstructions between the product and hub in an indoor environment.
 - away from electronic appliances such as TVs, radios, personal computers, wireless devices, or other phones.
 - facing away from radio frequency transmitters, such as external

For assistance, please visit <http://shop.panasonic.com/support> 5

Important Information

antennas of mobile phone cell stations. (Avoid putting the hub on a bay window or near a window.)

- If the reception for a hub location is not satisfactory, move the hub to another location for better reception.

Environment

- Keep the product away from electrical noise generating devices, such as fluorescent lamps and motors.
- The product should be kept free from excessive smoke, dust, high temperature, and vibration.
- The product should not be exposed to direct sunlight.
- Do not place heavy objects on top of the product.
- The product should be kept away from heat sources such as heaters, kitchen stoves, etc. It should not be placed in rooms where the temperature is less than 0 °C (32 °F) or greater than 40 °C (104 °F).
- Operating the product near electrical appliances may cause interference. Move away from the electrical appliances.

Other information

CAUTION: Risk of explosion if battery is replaced by an incorrect type. Dispose of used batteries according to the instructions.

Routine care

- Wipe the outer surface of the product with a soft moist cloth.
- Do not use benzine, thinner, or any abrasive powder.

Information on Disposal in other Countries outside the European Union



These symbols are only valid in the European Union. If you wish to discard these items, please contact your local authorities or dealer and ask for the correct method of disposal.

Note for the battery removal procedure

Refer to "Inserting the battery" on page 10.

6 For assistance, please visit <http://shop.panasonic.com/support>

Important Information

Notice

- This product is designed for use in the United States of America. Sale or use of this product in other countries may violate local laws.
- Cet appareil est conçu pour être utilisé aux États-Unis d'Amérique. La vente ou l'emploi de cet appareil dans certains autres pays peut constituer une infraction à la législation locale.
- Este producto está diseñado para usarse en los Estados Unidos de América. La venta o el empleo de este producto en ciertos países puede constituir violación de la legislación local.
- 本產品專為美國使用而設。若在其他國家銷售或使用，可能會違反當地法例。
- この製品は、日本国外での使用を目的として設計されており、日本国内での使用は法律違反となります。従って、当社では日本国内においては原則として修理などのサービスは致しかねます。

For assistance, please visit <http://shop.panasonic.com/support> 7

Setup



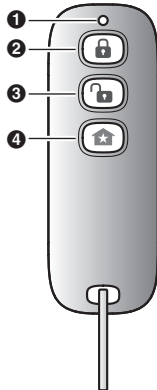

Part names and functions

■ Front view

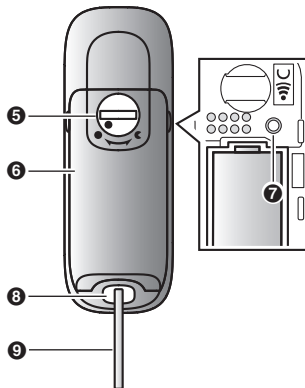

■ Rear view



- 1 LED indicator
- 2  (Arm: Away) button
Arms the alarm system using the **[Arm: Away]** mode.
- 3  (disarm) button
Disarms the alarm system.
- 4  (smart) button
Used to turn on a smart plug, trigger the alarm system, etc.
- 5 Battery cover lock
- 6 Battery cover
- 7  **[C]**
Used to register the keychain remote to the hub.
- 8 Key ring eyelet
- 9 Key ring

LED indicator

You can use the LED indicator to confirm the remote's status.

Indicator	Status
Off	Normal operation or no power ¹
Amber, blinking quickly	Signal is being sent to the hub (you are pressing a button) ²
Red, lit	[Arm: Away] mode selected (you pressed the arm button) ²
Green, lit	[Disarm] mode selected (you pressed the disarm button), or you pressed the smart button ²

8 For assistance, please visit <http://shop.panasonic.com/support>

Setup

Indicator	Status
Red, blinking	Remote is out of range of the hub, or could not communicate with the hub
Green, blinking slowly	Registration mode (you pressed and held [•)]C])
Repeating pattern of blinking green and blinking red	Low battery

- *1 The LED lights for about 2 seconds after a button is pressed, then turns off. If the LED indicator does not light when you press a button, the battery must be replaced.
- *2 The LED indicator does not indicate remote's status if the remote has not been registered (page 11).

4 Confirm the usage area

Read the information in this document to confirm that the desired usage area is suitable to proper operation.

Setup overview

1 Initial setup

Make sure you can access the system using your mobile device. For details, refer to the System Setup Guide included with your hub.

2 Insert the battery

The remote is battery powered.

3 Registration

Required only if the remote was purchased separately (i.e., not as part of a bundle).

For assistance, please visit <http://shop.panasonic.com/support> 9

Setup

Inserting the battery

- USE ONLY a CR2 Lithium battery.
- Confirm the polarities (+, -).
- Using a metal object to open the lock may scratch the lock.

- 1 Remove the battery cover.
 - Insert a thin, flat object into the battery cover lock and rotate it to the "unlocked" position, as shown below.



Locked Unlocked

- Grasp the indented areas on the sides of the battery cover (①) and lift the cover up (②).

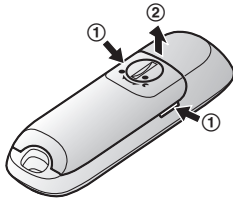

- 2 Insert the battery.

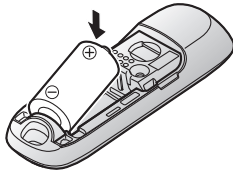

- 3 Attach and lock the battery cover.
 - After attaching the battery cover, rotate the lock to the "locked" position.

Attaching the key ring

Attach the key ring to the remote as shown.



Registering the remote

This procedure is not required for devices that were included as part of a bundle.

Before you can use the remote, it must be registered to the hub. If you purchased devices separately (i.e., not as part of a bundle), you must register each device to the hub.

You can register each device by using the registration buttons or the **[Home Network]** app.

Using registration buttons

- 1 **Hub:**
Press and hold **[••]C OTHER DEVICE]** until the LED indicator blinks slowly in green.
- 2 **Remote:**
Open the battery cover (page 10), then use an object with a thin tip, press and hold **[••]C]** until the LED indicator blinks slowly in green (page 8).
 - When registration is complete, the hub sounds one long beep.

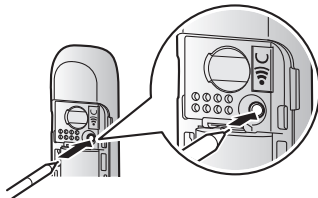

Note:

- To cancel without registering the remote, press **[••]C]** on the hub and on the remote again.
- If registration fails, the hub sounds several short beeps.

Using the app

When you register the remote by using the **[Home Network]** app, you can assign a name to your devices. For more information, refer to the User's Guide (page 12).

Wireless communication range

The wireless communication range of each device in the system from the hub is approximately 50 m (160 feet) indoors and approximately 300 m (1,000 feet) outdoors. Wireless communication may be unreliable when the following obstacles are located between the hub and other devices.

- Metal doors or screens
- Walls containing aluminum-sheet insulation
- Walls made of concrete or corrugated iron
- Double-pane glass windows
- Multiple walls
- When using each device on separate floors or in different buildings

For assistance, please visit <http://shop.panasonic.com/support> 11

Appendix



Using the remote

Changing the arm mode

Press the desired arm mode button.

- The LED indicator lights for about 2 seconds according to the arm mode (page 8).
- When the arm mode is changed with the keychain remote, the arm mode icons displayed on the app will not be automatically changed. The displayed arm mode icons will be updated when the app refreshes the home screen.

Canceling an alert

When the hub is sounding an alert, you can press  or  on the

keychain remote to cancel the alert.

- When the keychain remote cancels the alert, the LED indicator lights for about 2 seconds.

Using the smart button

You can press the keychain remote's smart button to turn on a smart plug, trigger the alarm system, etc.

Use the **[Home Network]** app to change the feature assigned to the smart button. For more information, refer to the User's Guide (page 12).

Features available when using the [Home Network] app

Some of the features that are available when using the **[Home Network]** app are listed below. For more information, refer to the User's Guide (page 12).

- **Alarm system**
You can use the app to arm and disarm the alarm system.
- **Device management**
You can use the app to change the remote's name and assign a feature to the keychain remote's smart button.

Accessing the User's Guide

The User's Guide is a collection of online documentation that helps you get the most out of the **[Home Network]** app.

1 iPhone®/iPad®

Tap  in the app's home screen.

Android™ devices

Tap  or press your mobile device's menu button in the app's home screen.

2 Tap [User's Guide].

Note:

- Microsoft® Windows® Internet Explorer® 8 and earlier versions are not supported.
- Android 4.1 or later versions are recommended.

- You can also access the User's Guide at the web page listed below.



www.panasonic.net/pcc/support/tel/homenetwork/manual/

Specifications

- **Standards**
DECT (Digital Enhanced Cordless Telecommunications)
 - **Frequency range**
DECT: 1.92 GHz – 1.93 GHz
 - **RF transmission power**
DECT: 115 mW (max.)
 - **Power source**
Lithium battery CR2 (1 × 3.0 V, 850 mAh)
 - **Operating conditions**
0 °C – 40 °C (32 °F – 104 °F)
 - **Battery life**
Approx. 2 years (when the remote is used 10 times a day, in an environment of 25 °C (77 °F))*¹
 - **Dimensions (height × width × depth)**
77 mm × 27 mm × 18 mm
(3 1/32 inches × 1 1/18 inches × 23/32 inches)
(without the key ring attached)
 - **Mass (weight)**
Approx. 17 g (0.04 lb), excluding the battery and without the key ring attached
- *¹ Battery life may be reduced depending on the operating environment, and whether the remote is used when it is out of range of the hub.

For assistance, please visit <http://shop.panasonic.com/support> 13

Appendix

FCC and other information

This device complies with Part 15 of the FCC Rules. Operation is subject to the following two conditions:

(1) This device may not cause harmful interference, and (2) this device must accept any interference received, including interference that may cause undesired operation.

Privacy of communications may not be ensured when using this device.

CAUTION:

Any changes or modifications not expressly approved by the party responsible for compliance could void the user's authority to operate this device.

NOTE:

This equipment has been tested and found to comply with the limits for a Class B digital device, pursuant to Part 15 of the FCC Rules. These limits are designed to provide reasonable protection against harmful interference in a residential installation. This equipment generates, uses, and can radiate radio frequency energy and, if not installed and used in accordance with the instructions, may cause harmful interference to radio communications. However, there is no guarantee that interference will not occur in a particular installation. If this equipment does cause harmful interference to radio or television reception, which can be determined by turning the equipment off and on, the user is encouraged to try to correct the

interference by one or more of the following measures:

- Reorient or relocate the receiving antenna.
- Increase the separation between the equipment and receiver.
- Connect the equipment into an outlet on a circuit different from that to which the receiver is connected.
- Consult the dealer or an experienced radio/TV technician for help.

Some devices operate at frequencies that may cause interference to nearby TVs and VCRs. To minimize or prevent such interference, this device should not be placed near or on top of a TV or VCR. If interference is experienced, move this device further away from the TV or VCR. This will often reduce or eliminate interference.

FCC RF Exposure Warning:

- This product complies with FCC radiation exposure limits set forth for an uncontrolled environment.
- This product may not be collocated or operated in conjunction with any other antenna or transmitter.
- For body-worn operation, the device must be used only with a non-metallic accessory. Use of other accessories may not ensure compliance with FCC RF exposure requirements.

Notice:

- FCC ID can be found inside the unit.

14 For assistance, please visit <http://shop.panasonic.com/support>

Customer services

Shop Accessories!

for all your Panasonic gear

Go to

<http://shop.panasonic.com/support>

Get everything you need to get the most out of
your Panasonic products

Accessories & Parts for your Camera, Phone, A/V
products, TV, Computers & Networking, Personal
Care, Home Appliances, Headphones, Batteries,
Backup Chargers & more...

Customer Services Directory

For Product Information, Operating Assistance,
Parts, Owner's Manuals, Dealer and Service info
go to <http://shop.panasonic.com/support>

You may also contact us directly at: 1-800-272-7033,

Monday - Friday 9 am to 9 pm;

Saturday - Sunday 10 am to 7 pm, EST.

For the hearing or speech impaired TTY: 1- 877-833-8855

As of June 2015

For assistance, please visit <http://shop.panasonic.com/support> 15

Appendix

Limited Warranty (ONLY FOR U.S.A.)

Panasonic Products Limited Warranty

Limited Warranty Coverage (For USA Only)

If your product does not work properly because of a defect in materials or workmanship, Panasonic Corporation of North America (referred to as "the warrantor") will, for the length of the period indicated on the chart below, which starts with the date of original purchase ("warranty period"), at its option either (a) repair your product with new or refurbished parts, (b) replace it with a new or a refurbished equivalent value product, or (c) refund your purchase price. The decision to repair, replace or refund will be made by the warrantor.

Product or Part Name	Parts	Labor
Home Network System Products	One (1) Year	One (1) Year
microSD card (Included model only)	90 days	N/A

During the "Labor" warranty period there will be no charge for labor. During the "Parts" warranty period, there will be no charge for parts. This Limited Warranty excludes both parts and labor for non-rechargeable batteries, antennas, and cosmetic parts (cabinet). This warranty only applies to products purchased and serviced in the United States. This warranty is extended only to the original purchaser of a new product which was not sold "as is".

Mail-In Service--Online Repair Request

Online Repair Request

To submit a new repair request and for quick repair status visit our Web Site at <http://shop.panasonic.com/support>

When shipping the unit, carefully pack, include all supplied accessories listed in the Owner's Manual, and send it prepaid, adequately insured and packed well in a carton box. When shipping Lithium Ion batteries please visit our Web Site at <http://shop.panasonic.com/support> as Panasonic is committed to providing the most up to date information. Include a letter detailing the complaint, a return address and provide a daytime phone number where you can be reached. A valid registered receipt is required under the Limited Warranty.

IF REPAIR IS NEEDED DURING THE WARRANTY PERIOD, THE PURCHASER WILL BE REQUIRED TO FURNISH A SALES RECEIPT/PROOF OF PURCHASE INDICATING DATE OF PURCHASE, AMOUNT PAID AND PLACE OF PURCHASE. CUSTOMER WILL BE CHARGED FOR THE REPAIR OF ANY UNIT RECEIVED WITHOUT SUCH PROOF OF PURCHASE.

16 For assistance, please visit <http://shop.panasonic.com/support>

Appendix

Limited Warranty Limits and Exclusions

This warranty **ONLY COVERS** failures due to defects in materials or workmanship, and **DOES NOT COVER** normal wear and tear or cosmetic damage. The warranty **ALSO DOES NOT COVER** damages which occurred in shipment, or failures which are caused by products not supplied by the warrantor, or failures which result from accidents, misuse, abuse, neglect, mishandling, misapplication, alteration, faulty installation, set-up adjustments, misadjustment of consumer controls, improper maintenance, power line surge, lightning damage, modification, introduction of sand, humidity or liquids, commercial use such as hotel, office, restaurant, or other business or rental use of the product, or service by anyone other than a Factory Service Center or other Authorized Servicer, or damage that is attributable to acts of God.

THERE ARE NO EXPRESS WARRANTIES EXCEPT AS LISTED UNDER "LIMITED WARRANTY COVERAGE".

THE WARRANTOR IS NOT LIABLE FOR INCIDENTAL OR CONSEQUENTIAL DAMAGES RESULTING FROM THE USE OF THIS PRODUCT, OR ARISING OUT OF ANY BREACH OF THIS WARRANTY.

(As examples, this excludes damages for lost time, travel to and from the servicer, loss of or damage to media or images, data or other memory or recorded content.

The items listed are not exclusive, but for illustration only.)

ALL EXPRESS AND IMPLIED WARRANTIES, INCLUDING THE WARRANTY OF MERCHANTABILITY, ARE LIMITED TO THE PERIOD OF THE LIMITED WARRANTY.

Some states do not allow the exclusion or limitation of incidental or consequential damages, or limitations on how long an implied warranty lasts, so the exclusions may not apply to you. This warranty gives you specific legal rights and you may also have other rights which vary from state to state. If a problem with this product develops during or after the warranty period, you may contact your dealer or Service Center. If the problem is not handled to your satisfaction, then write to:

Consumer Affairs Department
Panasonic Corporation of North America
661 Independence Pkwy
Chesapeake, VA 23320

PARTS AND SERVICE, WHICH ARE NOT COVERED BY THIS LIMITED WARRANTY, ARE YOUR RESPONSIBILITY.

As of June 2015

For assistance, please visit <http://shop.panasonic.com/support> 17

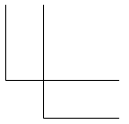
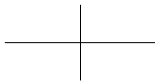
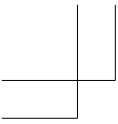

Notes

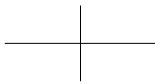
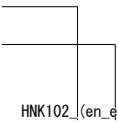
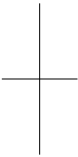

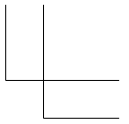
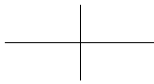
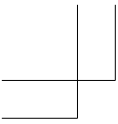

Notes

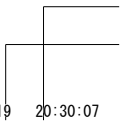
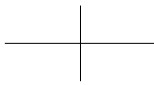
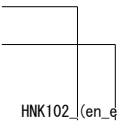
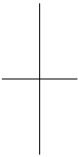

IMPORTANT!

If your product is not working properly. . .

- ① Use **CR2 Lithium battery**.
- ② Use the **Home Network app** to access the **User's Guide** and refer to the **Troubleshooting** section.



Visit our Web site: <http://shop.panasonic.com/support>
•FAQ and troubleshooting hints are available.

For your future reference

We recommend keeping a record of the following information to assist with any repair under warranty.

Serial No.	Date of purchase
------------	------------------

(found on the product's carton box) Name and address of dealer

Attach your purchase receipt here.

Panasonic Corporation of North America

Two Riverfront Plaza, Newark, NJ 07102-5490

© Panasonic System Networks Co., Ltd. 2015

Panasonic®

Manual de instrucciones

Sistema de red doméstico Control remoto llavero

Modelo n° **KX-HNK102**



Gracias por adquirir un producto Panasonic.

Este documento explica cómo operar el control remoto llavero de forma correcta.

Para obtener detalles sobre cómo usar el sistema, consulte la Guía del usuario (página 7).

Lea este documento antes de usar la unidad, y guárdelo para consultarlo en el futuro.

Para obtener ayuda, comuníquese con nosotros llamando al 1-800-272-7033 o visite nuestro sitio web: <http://shop.panasonic.com/support> para clientes en los EE. UU. (solo en inglés)

Por favor, registre su producto: <http://shop.panasonic.com/support>

Para utilizar este dispositivo:

- Descargue la versión más reciente de la aplicación **[Home Network]**.
- Actualice el hub a la versión de firmware más reciente (versión 5.50 o posterior). Para obtener más información, consulte la Guía del usuario (página 7).



PNQX7272ZA

PNQX7272ZA CC0615WK0 (E)





Tabla de Contenido

Configuración

Nombres de los componentes y funciones	3
Led indicador	4
Resumen de configuración	4
Insertar la batería	5
Sujetar el aro del llavero	5
Registrar el control remoto	6
Alcance de la comunicación inalámbrica	6

Apéndice

Usar el control remoto	7
Acceso a la Guía del usuario	7



Configuración

Nombres de los componentes y funciones

■ Vista de la parte frontal

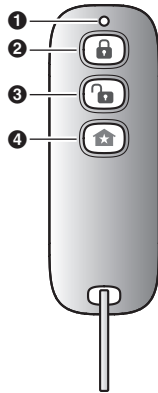

■ Vista de la parte posterior

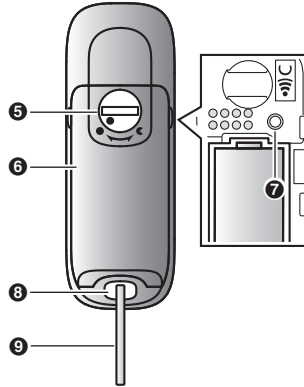

- 1 Led indicador
- 2 Botón (Armar: Fuera)
Arma el sistema de alarmas en el modo **[Armar: Fuera]**.
- 3 Botón (desarmar)
Desarma el sistema de alarmas.
- 4 Botón (inteligente)
Se utiliza para encender un enchufe inteligente, activar el sistema de alarmas, etc.
- 5 Seguro de la cubierta de la batería
- 6 Cubierta de la batería
- 7 **[(-)]C**
Se usa para registrar el control remoto llavero en el hub.
- 8 Ojal del llavero
- 9 Aro del llavero

Para obtener ayuda, visite <http://shop.panasonic.com/support> 3

Configuración

Led indicador

Puede usar el Led indicador para confirmar el estado del control remoto.

Indicador	Estado
Apagado	Operación normal o sin alimentación*1
Ámbar, parpadeo rápido	Se está enviando la señal al hub (está oprimiendo un botón)*2
Rojo, encendido	El modo [Armar: Fuera] está seleccionado (oprimió el botón de armado)*2
Verde, encendido	El modo [Desarmar] está seleccionado (oprimió el botón de desarmado) u oprimió el botón inteligente*2
Rojo, parpadeante	El control remoto está fuera del rango del hub o no pudo comunicarse con el hub
Verde, parpadeando lentamente	Modo de registro (oprimió y mantuvo oprimido [•)C])
Patrón repetitivo de parpadeo de luz verde y roja	Batería baja

*1 El Led indicador permanece encendido durante aproximadamente 2 segundos después de que se oprime un botón y luego se apaga. Si el Led indicador no se enciende cuando presiona un botón, debe reemplazarse la batería.

*2 El Led indicador no indica el estado remoto si el control remoto no se ha registrado (página 6).

Resumen de configuración

- 1 Configuración inicial**
Asegúrese de poder acceder al sistema mediante su dispositivo móvil. Para obtener más detalles, consulte la Guía de configuración del sistema que viene con su hub.
- 2 Inserte la batería**
El control remoto funciona con una batería.
- 3 Registro**
Solo se requiere si se compró el control remoto por separado (es decir, no como parte de un paquete).
- 4 Confirmación del área de uso**
Lea la información de este documento para confirmar que el área de uso deseada sea la adecuada para el correcto funcionamiento.

4 Para obtener ayuda, visite <http://shop.panasonic.com/support>

Configuración

Insertar la batería

- USE SOLO baterías de litio CR2.
- Verifique las polaridades (+, -).
- Uso de un objeto metálico para abrir el seguro puede rayar el seguro.

- 1 Elimine la tapa de la batería.
 - Inserte un objeto estrecho y plano dentro del seguro de la tapa de la batería y gírelo a la posición de "desbloqueo", según se muestra a continuación.



Bloqueado

Desbloqueo

- Sujete las áreas previstas a los costados de la tapa de la batería (①) y levante la tapa (②).

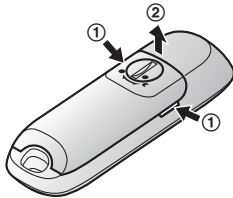

- 2 Inserte la batería.

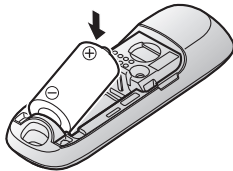

- 3 Sujete y bloquee la tapa de la batería.
 - Después de sujetar la tapa de la batería, gire el seguro a la posición de "bloqueo".

Sujetar el aro del llavero

Sujete el aro del llavero al control remoto según se muestra.



Para obtener ayuda, visite <http://shop.panasonic.com/support> 5

Configuración

Registrar el control remoto

Este procedimiento no es necesario para unidades que son parte de un paquete.

Antes de que pueda usar el control remoto, se debe registrar en el hub.

Si compró los dispositivos por separado (es decir, no como parte de un paquete), debe registrar cada dispositivo en el hub.

Puede registrar cada unidad mediante los botones de registro o la aplicación **[Home Network]**.

Uso de los botones de registro

- Hub:**
Oprima y mantenga oprimido **[OTHER DEVICE]** hasta que el Led indicador parpadee lentamente en verde.
- Control remoto:**
Abra la tapa de la batería (página 5), luego utilice un objeto de punta fina y mantenga oprimido **[OTHER DEVICE]** hasta que el Led indicador parpadee lentamente en verde (página 4).
 - Cuando se ha completado el registro, el hub emitirá un pitido largo.

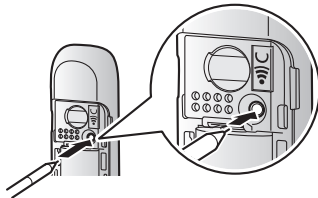

Nota:

- Para cancelar sin registrar el control remoto, oprima **[OTHER DEVICE]** en el hub y nuevamente en el control remoto.
- Si el registro falla, el hub emitirá varios pitidos cortos.

Uso de la aplicación

Cuando registre su control remoto con la aplicación **[Home Network]**, puede asignar un nombre a sus dispositivos. Para obtener más información, consulte la Guía del usuario (página 7).

Alcance de la comunicación inalámbrica

El alcance de la comunicación inalámbrica de cada dispositivo en el sistema del hub es de aproximadamente 50 m (160 pies) en interiores y de aproximadamente 300 m (1,000 pies) en el exterior. Es posible que la comunicación inalámbrica no sea tan confiable cuando se encuentran los obstáculos siguientes entre el hub y otros dispositivos.

- Puertas o pantallas metálicas
- Paredes que contengan aislamiento de aluminio
- Paredes de hormigón o hierro corrugado
- Ventanas de vidrio doble
- Varias paredes
- Cuando los dispositivos están en pisos o edificios diferentes

6 Para obtener ayuda, visite <http://shop.panasonic.com/support>



Usar el control remoto

Modificación del modo de armado

Oprima el botón del modo de armado que desee.

- El Led indicador se enciende durante aproximadamente 2 segundos, dependiendo del modo de armado (página 4).
- Cuando el modo de armado se cambia con el control remoto llavero, los iconos del modo de armado que aparecen en la aplicación no se cambiarán automáticamente. Los iconos del modo de armado que aparecen se actualizarán cuando la aplicación actualice la pantalla de inicio.

Cancelación de una alerta

Cuando el hub está haciendo sonar una alerta, puede oprimir  o  en el control remoto llavero para cancelar la alerta.

- Cuando el control remoto llavero cancele la alerta, el Led indicador permanecerá encendido durante 2 segundos.

Uso del botón inteligente

Puede oprimir el botón inteligente del control remoto llavero para encender un enchufe inteligente, activar el sistema de alarmas, etc.

Use la aplicación **[Home Network]** para cambiar la función asignada al enchufe inteligente. Para obtener más información, consulte la Guía del usuario (página 7).

Acceso a la Guía del usuario

La Guía del usuario es una colección de documentación en línea que lo ayuda a aprovechar al máximo la aplicación **[Home Network]**.

1 iPhone®/iPad®

Toque  en la pantalla de inicio de la aplicación.

Dispositivos Android™

Toque  u oprima el botón menú de su dispositivo en la pantalla de inicio de la aplicación.

2 Toque **[Guía del Usuario]**.

Nota:

- No se admite Microsoft® Windows® Internet Explorer® 8 y versiones anteriores.
- Se recomienda Android 4.1 y versiones posteriores.
- También puede acceder a la Guía del usuario mediante la página web a continuación.



www.panasonic.net/pcc/support/tel/homenetwork/manual/

Para obtener ayuda, visite <http://shop.panasonic.com/support> 7

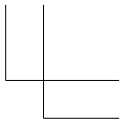
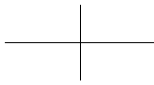
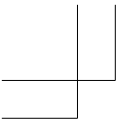

Notas

