

Panasonic®

Operating Instructions

Premium Design Phone

Model No. **KX-PRS120C**



*Before initial use, see “Getting Started”
on page 8.*

Thank you for purchasing a Panasonic product.

Please read these operating instructions before using the unit and save them for future reference.

For assistance, please visit our support page on:

<http://panasonic.ca/english/support>

<http://panasonic.ca/french/support>

Table of Contents

| | | |
|---|----|--|
| Introduction | | |
| Accessory information | 3 | |
| Important Information | | |
| For your safety | 5 | |
| Important safety instructions | 6 | |
| For best performance | 6 | |
| Other information | 7 | |
| Specifications | 7 | |
| Getting Started | | |
| Setting up | 8 | |
| Intelligent eco mode | 9 | |
| Controls | 10 | |
| Display icons | 10 | |
| Language setting | 11 | |
| Date and time | 11 | |
| Other settings | 12 | |
| Making/Answering Calls | | |
| Making calls | 13 | |
| Answering calls | 13 | |
| Useful features during a call | 13 | |
| Intercom | 15 | |
| Phonebook | | |
| Phonebook | 16 | |
| Speed dial | 18 | |
| Programming | | |
| Menu list | 20 | |
| Alarm | 26 | |
| Night mode | 26 | |
| Call block | 27 | |
| Baby monitor | 28 | |
| Other programming | 30 | |
| Registering a unit | 31 | |
| Call Display Service | | |
| Using Call Display service | 32 | |
| Caller list | 34 | |
| Answering System | | |
| Answering system | 35 | |
| Turning the answering system on/off | 35 | |
| Greeting message | 35 | |
| Listening to messages | 36 | |
| Advanced new message alerting features | 37 | |
| Remote operation | 38 | |
| Answering system settings | 39 | |
| Useful Information | | |
| Voice Mail service | 41 | |
| Error messages | 42 | |
| Troubleshooting | 43 | |
| Industry Canada Notices and other information | 47 | |
| Warranty | 48 | |
| Index | | |
| Index..... | 49 | |

Accessory information

Supplied accessories

| No. | Accessory item/Part number | Quantity |
|-----|----------------------------|----------|
| ① | AC adaptor/PNLV226-K | 1 |
| ② | Telephone line cord | 1 |
| ③ | Rechargeable batteries*1 | 2 |
| ④ | Handset cover*2 | 1 |

*1 See page 3 for replacement battery information.

*2 The handset cover comes attached to the handset.



Additional/replacement accessories

Please contact your nearest Panasonic dealer for sales information.

| Accessory item | Order number |
|------------------------|--|
| Rechargeable batteries | HHR-4DPA or HHR-4MYA*1 |
| | Battery type: – Nickel metal hydride (Ni-MH) – 2 x AAA (R03) size for each handset |
| Key detector | KX-TGA20*2 |

*1 Replacement batteries may have a different capacity from that of the supplied batteries.

*2 By registering the key detector (4 max.) to a Panasonic Digital Cordless Phone and attaching it to an easy-to-lose item in advance, you can locate and find the mislaid item to which the key detector is attached. Please visit our Web site:
<http://panasonic.net/pcc/products/telephone/p/tga20/>

Other information

- Design and specifications are subject to change without notice.
- The illustrations in these instructions may vary slightly from the actual product.

Introduction

Expanding your phone system

Handset (optional): KX-PRSA10C

You can expand your phone system by registering optional handsets (6 max.) to a single base unit.

- Optional handsets may be a different colour from that of the supplied handsets.



Important Information

For your safety

To prevent severe injury and loss of life/property, read this section carefully before using the product to ensure proper and safe operation of your product.

WARNING

Power connection

- Use only the power source marked on the product.
- Do not overload power outlets and extension cords. This can result in the risk of fire or electric shock.
- Completely insert the AC adaptor/power plug into the power outlet. Failure to do so may cause electric shock and/or excessive heat resulting in a fire.
- Regularly remove any dust, etc. from the AC adaptor/power plug by pulling it from the power outlet, then wiping with a dry cloth. Accumulated dust may cause an insulation defect from moisture, etc. resulting in a fire.
- Unplug the product from power outlets if it emits smoke, an abnormal smell, or makes an unusual noise. These conditions can cause fire or electric shock. Confirm that smoke has stopped emitting and contact us by visiting our support page on:
<http://panasonic.ca/english/support>
<http://panasonic.ca/french/support>
- Unplug from power outlets and never touch the inside of the product if its casing has been broken open.
- Never touch the plug with wet hands. Danger of electric shock exists.

Installation

- To prevent the risk of fire or electrical shock, do not expose the product to rain or any type of moisture.
- Do not place or use this product near automatically controlled devices such as automatic doors and fire alarms. Radio waves emitted from this product may cause such devices to malfunction resulting in an accident.

- Do not allow the AC adaptor or telephone line cord to be excessively pulled, bent or placed under heavy objects.

Operating safeguards

- Unplug the product from power outlets before cleaning. Do not use liquid or aerosol cleaners.
- Do not disassemble the product.
- Do not spill liquids (detergents, cleansers, etc.) onto the telephone line cord plug, or allow it to become wet at all. This may cause a fire. If the telephone line cord plug becomes wet, immediately pull it from the telephone wall jack, and do not use.

Medical

- Consult the manufacturer of any personal medical devices, such as pacemakers or hearing aids, to determine if they are adequately shielded from external RF (radio frequency) energy. (The product operates in the frequency range of 1.92 GHz to 1.93 GHz, and the RF transmission power is 115 mW (max.).)
- Do not use the product in health care facilities if any regulations posted in the area instruct you not to do so. Hospitals or health care facilities may be using equipment that could be sensitive to external RF energy.

CAUTION

Installation and location

- Never install telephone wiring during an electrical storm.
- Never install telephone line jacks in wet locations unless the jack is specifically designed for wet locations.
- Never touch uninsulated telephone wires or terminals unless the telephone line has been disconnected at the network interface.
- Use caution when installing or modifying telephone lines.
- The AC adaptor is used as the main disconnect device. Ensure that the AC outlet is installed near the product and is easily accessible.

Important Information

- This product is unable to make calls when:
 - the handset batteries need recharging or have failed.
 - there is a power failure.

Battery

- We recommend using the batteries noted on page 3. **USE ONLY rechargeable Ni-MH batteries AAA (R03) size.**
- Do not mix old and new batteries.
- Do not open or mutilate the batteries. Released electrolyte from the batteries is corrosive and may cause burns or injury to the eyes or skin. The electrolyte is toxic and may be harmful if swallowed.
- Exercise care when handling the batteries. Do not allow conductive materials such as rings, bracelets, or keys to touch the batteries, otherwise a short circuit may cause the batteries and/or the conductive material to overheat and cause burns.
- Charge the batteries provided with or identified for use with this product only, in accordance with the instructions and limitations specified in this manual.
- Only use a compatible base unit (or charger) to charge the batteries. Do not tamper with the base unit (or charger). Failure to follow these instructions may cause the batteries to swell or explode.

Attention:



A nickel metal hydride battery that is recyclable powers the product you have purchased. Please call 1-800-8-BATTERY (1-800-822-8837) for information on how to recycle this battery.

Important safety instructions

When using your product, basic safety precautions should always be followed to reduce the risk of fire, electric shock, and injury to persons, including the following:

1. Do not use this product near water for example, near a bathtub, washbowl, kitchen sink, or laundry tub, in a wet basement or near a swimming pool.
2. Avoid using a telephone (other than a cordless type) during an electrical storm. There may be a remote risk of electric shock from lightning.
3. Do not use the telephone to report a gas leak in the vicinity of the leak.
4. Use only the power cord and batteries indicated in this manual. Do not dispose of batteries in a fire. They may explode. Check with local codes for possible special disposal instructions.

SAVE THESE INSTRUCTIONS

For best performance

Base unit location/avoiding noise

The base unit and other compatible Panasonic units use radio waves to communicate with each other.

- For maximum coverage and noise-free communications, place your base unit:
 - at a convenient, high, and central location with no obstructions between the handset and base unit in an indoor environment.
 - away from electronic appliances such as TVs, radios, personal computers, wireless devices, or other phones.
 - facing away from radio frequency transmitters, such as external antennas of mobile phone cell stations. (Avoid putting the base unit on a bay window or near a window.)
- Coverage and voice quality depends on the local environmental conditions.

Important Information

- If the reception for a base unit location is not satisfactory, move the base unit to another location for better reception.

Environment

- Keep the product away from electrical noise generating devices, such as fluorescent lamps and motors.
- The product should be kept free from excessive smoke, dust, high temperature, and vibration.
- The product should not be exposed to direct sunlight.
- Do not place heavy objects on top of the product.
- When you leave the product unused for a long period of time, unplug the product from the power outlet.
- The product should be kept away from heat sources such as heaters, kitchen stoves, etc. It should not be placed in rooms where the temperature is less than 0 °C (32 °F) or greater than 40 °C (104 °F). Damp basements should also be avoided.
- The maximum calling distance may be shortened when the product is used in the following places: Near obstacles such as hills, tunnels, underground, near metal objects such as wire fences, etc.
- Operating the product near electrical appliances may cause interference. Move away from the electrical appliances.

Routine care

- **Wipe the outer surface of the product with a soft moist cloth.**
- Do not use benzine, thinner, or any abrasive powder.

Other information

CAUTION: Risk of explosion if battery is replaced by an incorrect type. Dispose of used batteries according to the instructions.

Notice for product disposal, transfer, or return

- This product can store your private/confidential information. To protect your privacy/confidentiality, we recommend that you erase information such as phonebook or caller list entries from the memory before you dispose of, transfer, or return the product.

Specifications

- **Standard:**
DECT 6.0 (Digital Enhanced Cordless Telecommunications 6.0)
- **Frequency range:**
1.92 GHz to 1.93 GHz
- **RF transmission power:**
115 mW (max.)
- **Power source:**
120 V AC, 60 Hz
- **Power consumption:**
Base unit:
Standby: Approx. 0.6 W
Maximum: Approx. 2.8 W
- **Operating conditions:**
0 °C – 40 °C (32 °F – 104 °F), 20 % – 80 % relative air humidity (dry)

Getting Started

Setting up

Connections

■ Base unit

- ① Connect the AC adaptor plug to the unit until you hear a click.
- ② Fasten the cord by hooking it.
- ③ Connect the AC adaptor to the power outlet.
- ④ Connect the telephone line cord to the unit until you hear a click.
- ⑤ Fasten the cord by hooking it.
- ⑥ Connect the telephone line cord to the single-line telephone jack (RJ11C) until you hear a click.
- ⑦ A DSL/ADSL filter (not supplied) is required if you have a DSL/ADSL service.

Note:

- Use only the supplied Panasonic AC adaptor PNLV226.

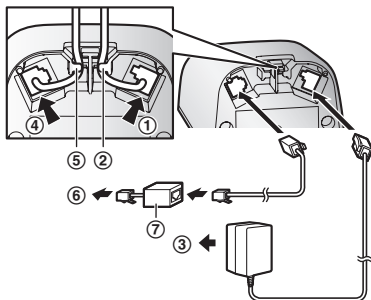

Battery installation

- USE ONLY rechargeable Ni-MH batteries AAA (R03) size (A).
- Do NOT use Alkaline/Manganese/Ni-Cd batteries.

- Confirm correct polarities (⊕, ⊖).

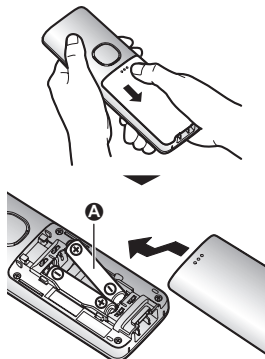

- Follow the directions on the display to set up the unit.

Battery charging

Charge for about 7 hours.

- Confirm “Charging” is displayed (A).
- When the batteries are fully charged, “Fully charged” is displayed.

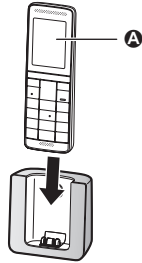

Note when setting up

Note for connections

- The AC adaptor must remain connected at all times. (It is normal for the adaptor to feel warm during use.)
- The AC adaptor should be connected to a vertically oriented or floor-mounted AC outlet. Do not connect the AC adaptor to a ceiling-mounted AC outlet, as the weight of the adaptor may cause it to become disconnected.

During a power failure

The unit will not work during a power failure. We recommend connecting a corded-type telephone line (without AC adaptor) to the same telephone line or to the same telephone line jack using a T-adaptor.

Note for battery installation

- Use the supplied rechargeable batteries. For replacement, we recommend using the Panasonic rechargeable batteries noted on page 3, 6.

Note for battery charging

- It is normal for the handset to feel warm during charging.

- Clean the charge contacts of the handset, base unit, and charger with a soft and dry cloth once a month. Before cleaning the unit, disconnect from power outlets and any telephone line cords. Clean more often if the unit is exposed to grease, dust, or high humidity.

Battery level

| Icon | Battery level |
|------|-----------------|
| | High |
| | Medium |
| | Low |
| | Needs charging. |
| | Empty |

Panasonic Ni-MH battery performance (supplied batteries)

| Operation | Operating time |
|----------------------|-----------------|
| In continuous use | 10 hours max.*1 |
| Not in use (standby) | 6 days max.*1 |

*1 If eco mode is on.

Note:

- Actual battery performance depends on usage and ambient environment.

Intelligent eco mode

This feature automatically reduces handset power consumption by suppressing handset transmission power when the handset is close to the base unit.

- When this feature is activated, **ECO** is displayed.
- Eco mode is turned off when the clarity booster is activated (page 14).

Getting Started

Controls

Handset

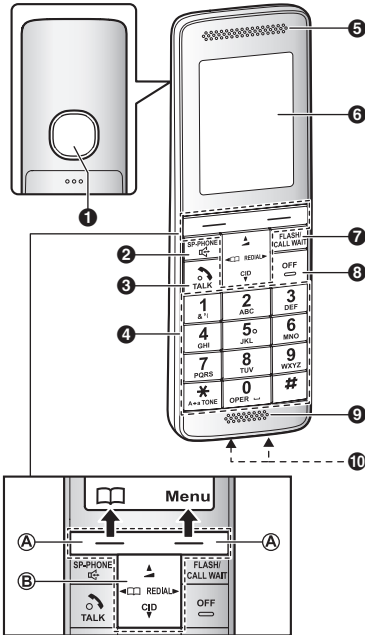

- 1 Speaker
- 2 [SP-PHONE: Speakerphone]
- 3 [TALK]
- 4 Dial keypad (☒): TONE
- 5 Receiver
- 6 Display
- 7 [FLASH][CALL WAIT]
- 8 [OFF]
- 9 Microphone
- 10 Charge contacts

Control type

Ⓐ Soft keys

By pressing a soft key, you can select the feature shown directly above it on the display.

Ⓑ Navigator key

- [▲], [▼], [◀], or [▶]: Scroll through various lists and items.
- [◀] (Volume: [▲] or [▼]): Adjust the receiver or speaker volume while talking.
- [▼] CID (Call Display): View the caller list.
- [◀] ☐☐: View the phonebook entry.
- [▶] REDIAL: View the redial list.

Base unit











- 1 [•••] (Locator)
 - You can locate a misplaced handset by pressing [•••].
- 2 Charge contacts



Display icons

Handset display items

| Item | Meaning |
|------|--|
| | Within base unit range |
| | Out of base unit range |
| | The line is in use. <ul style="list-style-type: none"> • When flashing slowly: The call is put on hold. • When flashing rapidly: An incoming call is now being received. |
| | Eco mode is on. (page 9) |
| | Noise reduction is set. (page 14) |

| Item | Meaning |
|---|--|
|  | Speakerphone is on. (page 13) |
|  | Answering system is on. (page 35) |
|  | Ringer volume is off. (page 22) |
|  | Night mode is on. (page 27) |
| PRIVACY | Privacy mode is on. (page 24) |
|  | Alarm is on. (page 26) |
| EQ | Equalizer is set. (page 14) |
|  | The key backlight is off. (page 23) |
| 1 | Handset number |
|  | Battery level |
|  | Blocked call (page 27) |
|  | Baby monitor is activated. The name/number displayed next to the icon indicates the monitoring unit. (page 28) |
| Booster on | Clarity booster is on. (page 14) |
| Line in use | Someone is using the line. |
| In use | Answering system is being used by another handset. |

Handset soft key icons

| Icon | Action |
|---|--|
|  | Temporarily turns off the ringer for incoming calls. (page 13) |
|  | Opens the phonebook. |

Language setting

Display language

You can select either “English” or “Français” as the display language. The default setting is “English”.

- [Menu]** (right soft key) **#1110**
- [↕]**: Select the desired setting. → **[Save]**
- [OFF]**

Voice guidance language

You can select either “English” or “Français” as the voice guidance language of the Talking Call Display and answering system. The default setting is “English”.

- [Menu]** (right soft key) **#1112**
- [↕]**: Select the desired setting.
- [Save]** → **[OFF]**

Date and time

- [Menu]** (right soft key) **#1101**
- Enter the current month, date, and year by selecting 2 digits for each.
Example: July 15, 2013
07 15 13
- [OK]**
- Enter the current hour and minute (12-hour clock format) by selecting 2 digits for each.
Example: 9:30
09 30
- [X]**: Select “AM” or “PM”.
- [Save]** → **[OFF]**

Note:

- When English is selected as the display language, 12-hour clock format is used. When French is selected, 24-hour clock format is used.

Getting Started

Other settings

Screen saver mode

The backlight goes dark when on a call or turns off completely after 1 minute of inactivity if the handset is not on the base unit or charger.

Activate the handset display again by:

- pressing [] when on a call.
- pressing [OFF] at all other times.

Dialing mode

If you cannot make calls, change this setting according to your telephone line service. The default setting is “Tone”.

“Tone”: For tone dial service.

“Pulse”: For rotary/pulse dial service.

- 1 [Menu] (right soft key) [#120]
- 2 [↕]: Select the desired setting.
- 3 [Save] → [OFF]

Making calls

- 1 Lift the handset and dial the phone number.
 - To correct a digit, press **[Clear]**.
- 2 Press **[↶]**.
- 3 When you finish talking, press **[OFF]** or place the handset on the base unit or charger.

Using the speakerphone

- 1 Dial the phone number and press **[☎]**.
- 2 When you finish talking, press **[OFF]**.

Note:

- To switch back to the receiver, press **[☎]/[↶]**.

Adjusting the receiver or speaker volume

Press **[▲]** or **[▼]** repeatedly while talking.

Making a call using the redial list

The last 5 phone numbers dialed are stored in the redial list (each 48 digits max.).

- 1 **[▶]** REDIAL
- 2 **[↕]**: Select the desired phone number.
- 3 **[↶]**

Erasing a number in the redial list

- 1 **[▶]** REDIAL
- 2 **[↕]**: Select the desired phone number.
→ **[Erase]**
- 3 **[↕]**: "Yes" → **[Select]** → **[OFF]**

Pause (for PBX/long distance service users)

A pause is sometimes required when making calls using a PBX or long distance service. When storing a calling card access number and/or PIN in the phonebook, a pause is also needed (page 18).

Example: If you need to dial the line access number "9" when making outside calls with a PBX:

- 1 **[9]** → **[▲]** (Pause)
- 2 Dial the phone number. → **[↶]**

Note:

- A 3.5 second pause is inserted each time **[▲]** (Pause) is pressed.

Answering calls

- 1 Lift the handset and press **[↶]** or **[☎]** when the unit rings.
- 2 When you finish talking, press **[OFF]** or place the handset on the base unit or charger.

Any key answer: You can answer the call by pressing any dial key.

Auto talk: You can answer calls simply by lifting the handset (page 23).

Temporary ringer off: You can turn the ringer off temporarily by pressing **[⌘]**.

Adjusting the handset ringer volume

Press **[▲]** or **[▼]** repeatedly to select the desired volume while ringing.

Useful features during a call

Hold

- 1 Press **[Menu]** during an outside call.
- 2 **[↕]**: "Hold" → **[Select]**
- 3 To release hold, press **[↶]**.

Note:

- After holding for 10 minutes, the call is disconnected.

Mute

- 1 Press **[Mute]** during a call.

Making/Answering Calls

- 2 To return to the call, press **[Mute]**.

Flash

[FLASH] allows you to use the special features of your host PBX such as transferring an extension call, or accessing optional telephone services.

Note:

- To change the flash time, see page 24.

For Call Waiting or Visual Call Waiting service users

To use Call Waiting or Visual Call Waiting, you must first subscribe with your service provider/telephone company.

This feature allows you to receive calls while you are already talking on the phone. If you receive a call while on the phone, you will hear a Call Waiting tone.

If you subscribe to both **Call Display** and **Visual Call Waiting services**, the 2nd caller's information is displayed after you hear the Call Waiting tone on the handset.

- 1 Press **[CALL WAIT]** to answer the 2nd call.
- 2 To switch between calls, press **[CALL WAIT]**.

Note:

- Please contact your service provider/telephone company for details and availability of this service in your area.

Temporary tone dialing (for rotary/pulse service users)

Press **[*]** (TONE) before entering access numbers which require tone dialing.

Handset clarity booster

This feature can improve sound clarity when the handset is used in an area where there may be interference. During an outside call, this feature is turned on automatically when necessary.

- When this feature is turned on, "**Booster on**" is displayed.

Handset noise reduction

This feature allows you to hear the voice of the person you are talking to clearly, by reducing the surrounding noise coming from the other party's telephone.

- 1 Press **[Menu]** while talking.
- 2 **[↕]**: "**Noise reduction on**" or "**Noise reduction off**" → **[Select]**

Note:

- Depending on the environment where this handset is being used, this feature may not be effective.
- This feature is not available using the speakerphone.

Handset equalizer

This feature clarifies the voice of the person you are talking to, producing a more natural-sounding voice that is easier to hear and understand.

- 1 Press **[Menu]** while talking.
- 2 **[↕]**: "**Equalizer**" → **[Select]**
- 3 **[↕]**: Select the desired setting.
- 4 Press **[OK]** to exit.

Note:

- Depending on the condition and quality of your telephone line, this feature may emphasize existing line noise. If it becomes difficult to hear, turn this feature off.
- This feature is not available while using the speakerphone.

Call share

You can join an existing outside call. To join the conversation, press **[📞]** when the other handset is on an outside call.

Note:

- A maximum of 3 parties (including 1 outside party) can join a conversation using 2 extensions. (**3-way conference**)

- To prevent other users from joining your conversations with outside callers, turn the privacy mode on (page 24).

Transferring calls, conference calls

Outside calls can be transferred between 2 handsets in the same radio cell.
2 handsets in the same radio cell can have a conference call with an outside party.

- 1 During an outside call, press **[Menu]**.
- 2 **[↕]**: "Intercom" → **[Select]**
- 3 **[↕]**: Select the desired unit. → **[Select]**
- 4 Wait for the paged party to answer.
 - If the paged party does not answer, press **[Back]** to return to the outside call.
- 5 **To complete the transfer:**
Press **[OFF]**.
To establish a conference call:
[Menu] → **[↕]**: "Conference" → **[Select]**
 - To leave the conference, press **[OFF]**.
The other 2 parties can continue the conversation.
 - To put the outside call on hold:
[Menu] → **[↕]**: "Hold" → **[Select]**
To resume the conference: **[Menu]** → **[↕]**: "Conference" → **[Select]**
 - To cancel the conference: **[Menu]** → **[↕]**: "Stop conference" → **[Select]**
You can continue the conversation with the outside caller.

Intercom

Intercom calls can be made between handsets.

Note:

- When paging the handset, the paged handset beeps for 1 minute.
- If you receive an outside call while talking on the intercom, you hear 2 tones. To answer the call, press **[OFF]**, then press **[↶]**.

Making an intercom call

- 1 **[Menu]** (right soft key) → **[Intercom]**
- 2 **[↕]**: Select the desired unit. → **[Select]**
- 3 When you finish talking, press **[OFF]**.

Answering an intercom call

- 1 Press **[↶]** to answer the page.
- 2 When you finish talking, press **[OFF]**.

Turning auto intercom on/off

This feature allows the handset to answer intercom calls automatically when it is called. You do not need to press **[↶]**. When this feature is set to "on", the monitoring handset for the baby monitor feature (page 29) will also answer baby monitor calls automatically. The default setting is "off".

- 1 **[Menu]** (right soft key) **[#]** **[2]** **[7]** **[3]**
- 2 **[↕]**: Select the desired setting. → **[Save]** → **[OFF]**

Phonebook

Phonebook

You can add 300 names (16 characters max.) and phone numbers (24 digits max.) to the phonebook, and assign each phonebook entry to the desired group.

The total number of entries that can be stored varies depending on how many phone numbers you have stored for each entry. Total number of entries is shown below*1:
 1 name + 1 phone number: 300 entries
 1 name + 2 phone numbers: 150 entries
 1 name + 3 phone numbers: 100 entries
 *1 Up to 3 phone numbers for each entry can be stored.

Important:

- All entries can be shared by any registered handset.

Adding phonebook entries

- 1 [□] or [◀] □ → [Menu]
- 2 [↕]: "Add new entry" → [Select]
- 3 [↕]: "(Name)" → [Select]
- 4 Enter the party's name. → [OK]
- 5 [↕]: "(Phone no. 1)" → [Select]
 - You can store up to 3 phone numbers for each entry.
- 6 Enter the party's phone number. → [OK]
- 7 [↕]: "Group 1" → [Select]
- 8 [↕]: Select the desired group. → [Select]
- 9 [Save] → [OFF]

Character table for entering names

While entering characters, you can switch between uppercase and lowercase by pressing [↔] (A→a).

| Key | Character |
|-----|------------------------|
| [1] | & ' () * , - . / 1 |

| Key | Character |
|-----|------------------------|
| [2] | A B C 2 a b c 2 |
| [3] | D E F 3 d e f 3 |
| [4] | G H I 4 g h i 4 |
| [5] | J K L 5 j k l 5 |
| [6] | M N O 6 m n o 6 |
| [7] | P Q R S 7 p q r s 7 |
| [8] | T U V 8 t u v 8 |
| [9] | W X Y Z 9 w x y z 9 |
| [0] | ␣ 0 |
| [#] | # |

- To enter another character that is located on the same dial key, first press [▶] to move the cursor to the next space.
- If you do not press any dial key within 5 seconds after entering a character, the character is fixed and the cursor moves to the next space.
- ␣ in the above table represents a single space.

Erasing the character or number

Press [◀] or [▶]. → [Clear]

- Press and hold [Clear] to erase all characters or numbers.

Storing a redial list number to the phonebook

- 1 [▶] REDIAL
- 2 [↕]: Select the desired phone number. → [Detail] → [Save]
- 3 To store the name, continue from step 3, "Editing entries", page 17.

Storing caller information to the phonebook

- 1 [▼] CID
- 2 [↕]: Select the desired entry. → [Detail]
 - To edit the number: [Menu] → [↕]: "Edit" → [Select]

Press [Edit] repeatedly until the phone number is shown in the desired format. And then, press [Save]. Go to step 5.
- 3 [Menu]
- 4 [↕]: "Save CID" → [Select]
- 5 [↕]: "Phonebook" → [Select]
- 6 Continue from step 3, "Editing entries", page 17.

Groups

Groups can help you find entries in the phonebook quickly and easily. You can change the names of groups ("Friends", "Family", etc.). By assigning different ringer tones for different groups of callers, you can identify who is calling (ringer ID), if you have subscribed to Call Display service.

Changing group names/setting ringer ID

- 1 [□□] or [←] □□ → [Menu]
- 2 [↕]: "Group" → [Select]
- 3 [↕]: Select the desired group. → [Select]
- 4 **To change group names**
 [↕]: "Group name" → [Select] → Edit the name (10 characters max.; page 16). → [Save]
To set group ringer tone
 [↕]: Select the current setting of the group ringer tone. → [Select] → [↕]: Select the desired ringer tone. → [Save]
- 5 [OFF]

Finding and calling from a phonebook entry

- 1 [□□] or [←] □□
- 2 **To scroll through all entries**
 [↕]: Select the desired entry. → [↶]
To search by first character
 - ① Press the dial key ([0] to [9], or [#]) which contains the character you are searching for (page 16).
 - ② [↕]: Scroll through the phonebook if necessary. → [↶]**To search by query**
 - ① [X] → To search for the name, enter the first characters (up to 4) in uppercase (page 16). → [OK]
 - ② [↕]: Scroll through the phonebook if necessary. → [↶]**To search by group**
 - ① [Group]
 - ② [↕]: Select the desired group. → [Select]
 - ③ [↕]: Scroll through the phonebook if necessary. → [↶]
- 3 [↕]: Select the desired phone number. → [↶]

Editing entries

- 1 Find the desired entry (page 17). → [Menu]
- 2 [↕]: "Edit" → [Select]
- 3 [↕]: Select the desired item you want to change. → [Select]
- 4 **To change the name and phone number:**
 Edit the name or phone number. → [OK]
To change the group:
 [↕]: Select the desired group. → [Select]
- 5 [Save] → [OFF]

Erasing entries

Erasing an entry

- 1 Find the desired entry (page 17). → [Menu]

Phonebook

- 2 [↕]: "Erase" → [Select]
- 3 [↕]: "Yes" → [Select] → [OFF]

Erasing all entries

- 1 [□□] or [←] □□ → [Menu]
- 2 [↕]: "Erase all" → [Select]
- 3 [↕]: "Yes" → [Select]
- 4 [↕]: "Yes" → [Select] → [OFF]

Chain dial

This feature allows you to dial phone numbers in the phonebook while you are on a call. This feature can be used, for example, to dial a calling card access number or bank account PIN that you have stored in the phonebook, without having to dial manually.

- 1 During an outside call, press [Menu].
- 2 [↕]: "Phonebook" → [Select]
- 3 [↕]: Select the desired entry. → [Select]
- 4 [↕]: Select the desired phone number.
- 5 Press [Call] to dial the number.

Note:

- When storing a calling card access number and your PIN in the phonebook as one phonebook entry, press [▲] (Pause) to add pauses after the number and PIN as necessary (page 13).
- If you have rotary/pulse service, you need to press [☒] (TONE) before pressing [Menu] in step 1 to change the dialing mode temporarily to tone. When adding entries to the phonebook, we recommend adding [☒] (TONE) to the beginning of phone numbers you wish to chain dial (page 16).

Speed dial

You can assign 1 phone number to each of the dial keys ([1] to [9]) on the handset.

Adding phone numbers to speed dial keys

■ By entering phone numbers:

- 1 Press and hold the desired speed dial key ([1] to [9]). → [Add]
- 2 [↕]: "Manual" → [Select]
- 3 Enter the party's name (16 characters max.; page 16). → [OK]
- 4 Enter the party's phone number (24 digits max.). → [OK] → [Select] → [OFF]

■ From the phonebook:

- 1 Press and hold the desired speed dial key ([1] to [9]). → [Add]
- 2 [↕]: "Phonebook" → [Select]
- 3 [↕]: Select the desired entry. → [Select]
- 4 [↕]: Select the desired phone number.
- 5 [Save] → [OFF]

Note:

- If you edit a phonebook entry which is assigned to a speed dial key, the edited entry does not transfer to the speed dial key.

Editing an entry

- 1 Press and hold the desired speed dial key ([1] to [9]). → [Menu]
- 2 [↕]: "Edit" → [Select]
- 3 Edit the name if necessary. → [OK]
- 4 Edit the phone number if necessary. → [OK] → [Select] → [OFF]

Erasing an entry

- 1 Press and hold the desired speed dial key ([1] to [9]). → [Menu]
- 2 [↕]: "Erase" → [Select]
- 3 [↕]: "Yes" → [Select] → [OFF]

Viewing an entry/Making a call

- 1 Press and hold the desired speed dial key ([1] to [9]).
- 2 To make a call, press [📞].

Programming

Menu list

To access the features, there are 2 methods.

■ Scrolling through the display menus

- 1 **[Menu]** (right soft key)
- 2 Press **[▼]**, **[▲]**, **[▶]**, or **[◀]** to select the desired main menu. → **[Select]**
- 3 Press **[▼]** or **[▲]** to select the desired item from the next sub-menus. → **[Select]**
- 4 Press **[▼]** or **[▲]** to select the desired setting. → **[Save]**

■ Using the direct command code

- 1 **[Menu]** (right soft key) → Enter the desired code.
Example: Press **[Menu]** (right soft key) **#1101**.
- 2 Select the desired setting. → **[Save]**

Note:

- To exit the operation, press **[OFF]**.
- In the following table, < > indicates the default settings.
- In the following table,  indicates the reference page number.
- Display menu order and sub-menu may vary depending on your model.

Display the menu tree and direct command code table

Main menu:  "Caller list"

| Operation | Code |  |
|--------------------------|------|---|
| Viewing the caller list. | #213 | 34 |

Main menu:  "Answering device"

| Sub-menu 1 | Sub-menu 2 | Settings | Code |  |
|---------------------------------|--|----------|------|---|
| Message list | – | – | #329 | 36 |
| Play new message | – | – | #323 | 36 |
| Play all message | – | – | #324 | 36 |
| Erase all message* ¹ | – | – | #325 | 37 |
| Greeting | Record greeting* ¹ | – | #302 | 35 |
| | Check greeting | – | #303 | 36 |
| | Pre-recorded* ¹ (Reset to pre-recorded greeting) | – | #304 | 35 |

Programming

| Sub-menu 1 | Sub-menu 2 | Settings | Code |  |
|--------------------------|--|--|------|---|
| New message alert | Outgoing call ^{*1} – On/Off | 1: On 0: <Off> | #338 | 37 |
| | Outgoing call ^{*1} – Notification to | – | | |
| | Outgoing call ^{*1} – Remote code | 1: Activate 0: <Inactivate> | | |
| | Handset beep | 1: On 0: <Off> | #339 | 37 |
| Settings | Ring count ^{*1} | 2-7: 2-7 rings 4: <4 rings> 0: Toll saver | #211 | 40 |
| | Recording time ^{*1} | 1: 1 min 3: <3 min> 0: Greeting only ^{*2} | #305 | 40 |
| | Remote code ^{*1} | <111> | #306 | 38 |
| | Screen call | 1: <On> 0: Off | #310 | 39 |
| Answer on ^{*1} | – | – | #327 | 35 |
| Answer off ^{*1} | – | – | #328 | 35 |

Main menu:  “Voice Mail access”

| Operation | Code |  |
|-----------------------------------|------|---|
| Listening to Voice Mail messages. | #330 | 41 |

Main menu:  “Intercom”

| Operation | Code |  |
|--------------------------|------|---|
| Paging the desired unit. | #274 | 15 |

Main menu:  “Set date & time”

| Sub-menu 1 | Sub-menu 2 | Settings | Code |  |
|-----------------------------------|---------------|--|------|---|
| Date and time ^{*1} | – | – | #101 | 11 |
| Memo alarm | 1-5: Alarm1-5 | 1: Once 2: Daily 3: Weekly 0: <Off> | #720 | 26 |
| Time adjustment ^{*1, *3} | – | 1: <Caller ID auto> 0: Manual | #226 | – |

Programming

Main menu:  "Settings"

| Sub-menu 1 | Sub-menu 2 | Settings | Code |  |
|--|-----------------------------------|--|---------------------|---|
| Ring adjustments | Ringer volume | 0-6: Off-6 <6> | #160 | - |
| | Ringer tone ^{*4, *5} | <Tone 1> | #161 | - |
| | Night mode - On/Off | 1: On 0: <Off> | #238 | 27 |
| | Night mode - Start/End | <11:00 PM/06:00 AM> | #237 | 27 |
| | Night mode - Select group | 1-9: Group 1-9 | #241 | 27 |
| Set date & time | Date and time ^{*1} | - | #101 | 11 |
| | Memo alarm - 1-5: Alarm1-5 | 1: Once 2: Daily 3: Weekly 0: <Off> | #720 | 26 |
| | Time adjustment ^{*1, *3} | 1: <Caller ID auto> 0: Manual | #226 | - |
| Talking Caller ID (Talking Call Display) | - | 1: <On> 0: Off | #162 | 32 |
| Handset name | - | - | #104 | 30 |
| Key detector setting ⁶ - 1: Add new device (for Detector1) ⁷ - 2: Add new device (for Detector2) - 3: Add new device (for Detector3) - 4: Add new device (for Detector4) | Change name ^{*1} | Detector1 | #6561 | - |
| | | Detector2 ^{*8} | #6562 ^{*9} | |
| | | Detector3 ^{*8} | #6563 ^{*9} | |
| | | Detector4 ^{*8} | #6564 ^{*9} | |
| | Registration | - | #6571 | - |
| | | | #6572 ^{*9} | |
| | | | #6573 ^{*9} | |
| | Deregistration | - | #6574 ^{*9} | - |
| | | | #6581 | |
| | | | #6582 ^{*9} | |
| | | | #6583 ^{*9} | |
| | | | #6584 ^{*9} | |

Programming

| Sub-menu 1 | Sub-menu 2 | Settings | Code |  |
|--------------------------|---|--|------|---|
| Call block ^{*1} | – | – | #217 | 27 |
| | First ring ^{*1} | 1: <On> 0: Off | #173 | 28 |
| | Block w/o num ^{*1, *2} (Block calls without phone number) | 1: On 0: <Off> | #240 | 28 |
| Speed dial | – | – | #261 | 18 |
| Voice mail | Save VM access# ^{*1} (VM: Voice Mail) | – | #331 | 41 |
| | VM tone detect ^{*1} | 1: <On> 0: Off | #332 | 41 |
| Display | Wallpaper | <Wallpaper1> | #181 | – |
| | Clock ^{*10} | 1: Analog (Small) 2: Analog (Large) 3: <Digital (Large)> 4: Digital (Small) 0: Off | #198 | – |
| | Display colour | 1: <Colour1> 2: Colour2 | #182 | – |
| | Display mode ^{*11} | 1: <Multi items> 0: Single item | #192 | – |
| | Key backlight | 1: <On> 0: Off | #276 | – |
| | LCD backlight ^{*12} | 1: <On> 0: Off | #191 | – |
| | LCD contrast (Display contrast) | 1-6: Contrast 1-6 <Contrast 3> | #145 | – |
| Auto intercom | – | 1: On 0: <Off> | #273 | 15 |
| Key tone | – | 1: <On> 0: Off | #165 | – |
| Auto talk ^{*13} | – | 1: On 0: <Off> | #200 | 13 |

Programming

| Sub-menu 1 | Sub-menu 2 | Settings | Code | |
|-------------------------------|---|--|------|----|
| Set tel line | Set dial mode* ¹ | 1: Pulse 2: <Tone> | #120 | 12 |
| | Set flash time* ^{1,14} | 0: 900 ms 1: <700 ms> 2: 600 ms 3: 400 ms 4: 300 ms 5: 250 ms *: 200 ms #: 160 ms 6: 110 ms 7: 100 ms 8: 90 ms 9: 80 ms | #121 | 14 |
| | Set line mode* ^{1,15} | 1: A 2: | #122 | – |
| | C. WTG options* ¹ (Call Waiting Deluxe options) | 1: On 0: <Off> | #215 | 32 |
| Privacy mode* ^{1,16} | – | 1: On 0: <Off> | #194 | 14 |
| Registration | Register handset | – | #130 | 31 |
| | Deregistration* ² | – | #131 | 31 |
| Customer support | – | – | #680 | – |
| Change language | Display | 1: <English> 2: Français | #110 | 11 |
| | Voice prompt* ¹ | 1: <English> 2: Français | #112 | 11 |

Main menu: “Baby monitor”

| Sub-menu 1 | Sub-menu 2 | Settings | Code | |
|-------------------|------------|----------------------------------|------|----|
| On/Off | – | 1: On 0: <Off> | #268 | 28 |
| Sensitivity level | – | 1: Low 2: <Middle> 3: High | #269 | 29 |

Main menu: “Calendar”

| Operation | Code | |
|--|------|----|
| Viewing the calendar and setting the schedule alarm. | #727 | 30 |

Programming

Main menu:  "Key detector"^{*6}

| Sub-menu 1 | Sub-menu 2 | Settings | Code |  |
|---------------|------------|----------|------|---|
| Search | – | – | #655 | – |
| Battery check | – | – | | |

Main menu:  "Ring adjustments"^{*17}

| Sub-menu 1 | Sub-menu 2 | Settings | Code |  |
|-------------------------------|--------------|---------------------|------|---|
| Ringer volume | – | 0-6: Off-6 <6> | #160 | – |
| Ringer tone ^{*4, *5} | – | <Tone 1> | #161 | – |
| Night mode | On/Off | 1: On 0: <Off> | #238 | 27 |
| | Start/End | <11:00 PM/06:00 AM> | #237 | 27 |
| | Select group | 1-9: Group 1-9 | #241 | 27 |

- *1 If you program these settings using one of the handsets, you do not need to program the same item using another handset.
- *2 This menu is not displayed when scrolling through the display menus. It is only available in direct command code.
- *3 This feature allows the unit to automatically adjust the date and time each time caller information including date and time is received.
To turn this feature on, select "Caller ID auto". To turn this feature off, select "Manual". (Call Display subscribers only)
To use this feature, set the date and time first (page 11).
- *4 If you subscribe to a distinctive ring service, select a tone (tone 1 to 2). If you select a melody, you cannot distinguish lines by their ringers.
- *5 The preset melodies in this product ("Tone 3" - "Melody 30") are used with permission of © 2012 Copyrights Vision Inc.
- *6 This setting is available when you have the key detector (KX-TGA20). Read the installation manual for more information on the key detector.
- *7 For models with supplied key detectors, the display shows "1:Detector1".
- *8 If you register 2 or more key detectors.
- *9 If you have 2 or more key detectors.
- *10 Wallpaper is displayed in the standby mode only when you select "Digital (Small)" or "Off" for this setting.
- *11 You can select to display either a single item or multiple items on one screen at a time for the handset main menu icons in function menu, recorded message list, phonebook list, caller list, and redial list.
- *12 You can set the handset display backlight while on charge.
– "On": Backlight is on (dimmed).
– "Off": Backlight turns off after 10 seconds of charging.
- *13 If you subscribe to a Call Display service and want to view the caller's information after lifting up the handset to answer a call, turn off this feature.
- *14 The flash time depends on your telephone exchange or host PBX. Contact your PBX supplier if necessary.

Programming

- *15 Generally, the line mode setting should not be changed. This setting automatically maintains receiver volume at the proper level depending on the current telephone line condition. Set the line mode to “**A**” if telephone line condition is not good.
- *16 To prevent other users from joining your conversations with outside callers, turn this feature on.
- *17 This menu icon is displayed when the key detector is not registered.

Alarm

An alarm sounds at the set time for 1 minute and is repeated 5 times at 5 minute intervals (snooze function). A text memo can also be displayed for the alarm. A total of 5 separate alarm times can be programmed for each handset. You can set one of 3 different alarm options (once, daily, or weekly) for each alarm time.

Important:

- Make sure the unit's date and time setting is correct (page 11).

- 1 **[Menu]** (right soft key) **[#][7][2][0]**
- 2 Select an alarm by pressing **[1]** to **[5]**. → **[Select]**
- 3 **[↕]**: Select the desired alarm option. → **[Select]**

| |
|--|
| “Off” Turns alarm off. Go to step 10. |
| “Once” An alarm sounds once at the set time. |
| “Daily” An alarm sounds daily at the set time. Go to step 5. |
| “Weekly” Alarm sounds weekly at the set time(s). |

- 4 Proceed with the operation according to your selection in step 3.
 - **Once:**
Enter the desired month and date. → **[OK]**
 - **Weekly:**
[↕]: Select the desired day of the week and press **[Select]**. → **[OK]**

- 5 Set the desired time.
- 6 **[☒]**: Select “**AM**” or “**PM**”. → **[OK]**
- 7 Enter a text memo (30 characters max.). → **[OK]**
- 8 **[↕]**: Select the desired alarm tone. → **[Select]**
 - We recommend selecting a different ringer tone from the one used for outside calls.
- 9 **[↕]**: Select the desired snooze setting. → **[Select]**
- 10 **[Select]** → **[OFF]**

Note:

- Press **[Stop]** to stop the alarm completely.
- When the handset is in use, the alarm will not sound until the handset is in standby mode.
- Press any dial key or **[Snooze]** to stop the sound but keep the snooze function activated.
- If you want to make an outside call when the snooze function is activated, please stop the snooze function before making the call.

Night mode

Night mode allows you to select a period of time during which the handset will not ring for outside calls. This feature is useful for time periods when you do not want to be disturbed, for example, while sleeping. Night mode can be set for each handset.

Using the phonebook's group feature (page 17), you can also select groups of callers whose calls override night mode and ring the handset (Call Display subscribers only).

Important:

- Make sure the unit's date and time setting is correct (page 11).
- If you have set the alarm, the alarm sounds even if the night mode is turned on.

Turning night mode on/off

- 1 **[Menu]** (right soft key) **#238**
- 2 **[↓]**: Select the desired setting. → **[Save]**
 - If you select "OFF", press **[OFF]** to exit.
- 3 Enter the desired hour and minute you wish to start this feature.
- 4 **[*]**: Select "AM" or "PM". → **[OK]**
- 5 Enter the desired hour and minute you wish to end this feature.
- 6 **[*]**: Select "AM" or "PM".
- 7 **[Save]** → **[OFF]**

Changing the start and end time

- 1 **[Menu]** (right soft key) **#237**
- 2 Continue from step 3, "Turning night mode on/off", page 27.

Selecting groups to bypass night mode

- 1 **[Menu]** (right soft key) **#241**
- 2 Select your desired groups by pressing **1** to **9**.
 - "✓" is displayed next to the selected group numbers.
 - To cancel a selected group, press the same dial key again. "✓" disappears.
- 3 **[Save]** → **[OFF]**

Call block

This feature allows the unit to reject calls when:

- the unit receives a call from a phone number stored in the call block list as unwanted ("Storing unwanted callers", page 27).

- the unit receives a call without phone number ("Blocking incoming calls without phone number", page 28).

When a call is received, the unit rings for a short time*1 while the caller is being identified. If the phone number matches an entry in the call block list, the unit emits no sound to the caller, and disconnects the call. (Call Display subscribers only)

*1 This is called first ring. If you do not want the first ring to sound, turn this setting to "OFF" (page 28).

Important:

- When the unit receives a call from a number that is stored in the call block list or a call without a recognized phone number, the call is logged in the caller list (page 34) with **[*]** after the call is disconnected.

Storing unwanted callers

You can store up to 100 phone numbers in the call block list.

Important:

- You must store the phone number with an area code in the call block list.

■ From the caller list:

- 1 **[v]** CID
- 2 **[↓]**: Select the entry to be blocked. → **[Detail]**
 - To edit the number: **[Menu]** → **[↓]**: "Edit" → **[Select]**
Press **[Edit]** repeatedly until the phone number is shown in the 10-digit format. And then, press **[Save]**. Go to step 5.

- 3 **[Menu]**
- 4 **[↓]**: "Save CID" → **[Select]**
- 5 **[↓]**: "Call block" → **[Select]**
- 6 **[↓]**: "Yes" → **[Select]**
- 7 Edit the phone number if necessary (24 digits max.).
- 8 **[Save]** → **[OFF]**

■ By entering phone numbers:

- 1 **[Menu]** (right soft key) **#217**

Programming

- 2 **[Menu]** → **[↕]**: “Add” → **[Select]**
- 3 Enter the phone number (24 digits max.).
- 4 **[Save]** → **[OFF]**

Blocking incoming calls without phone number

You can reject a call when no phone number is provided, such as a call just showing “Unavailable Name & No.”.

- 1 **[Menu]** (right soft key) **#240**
- 2 **[↕]**: Select the desired setting. → **[Save]**
- 3 **[OFF]**

Setting the first ring for the call block list

If you do not want the first ring from a number on the call block list to sound, turn the first ring setting to “Off”. The default setting is “On”.

- 1 **[Menu]** (right soft key) **#173**
- 2 **[↕]**: Select the desired setting. → **[Save]**
- 3 **[OFF]**

Viewing/editing/erasing call block numbers

- 1 **[Menu]** (right soft key) **#217**
- 2 **[↕]**: Select the desired entry.
 - To exit, press **[OFF]**.
- 3 **To edit a number:**
[Edit] → Edit the phone number. → **[Save]** → **[OFF]**
To erase a number:
[Erase] → **[↕]**: “Yes” → **[Select]** → **[OFF]**

Baby monitor

This feature allows you to listen in on a room where another handset is located, allowing you to easily monitor from different areas of the house or place. The monitored handset (placed in a baby’s room, for example) will automatically call the monitoring handset or

the phone number stored when it detects sound.

Important:

- You should perform a test run of the baby monitor procedure to ensure that the baby monitor feature is set correctly. For example, test its sensitivity. Check the connection if you are diverting the baby monitor to an outside line.

Note:

- If the unit is connected to a PBX system, you cannot set the baby monitor.
- During the monitoring mode, battery consumption is faster than usual. We recommend leaving the monitored handset on the base unit or charger.
- The monitored handset never rings during the monitoring mode.

Setting the baby monitor

Perform the setting operation with the handset to be monitored (for example, the handset placed in a baby’s room).

To monitor with a handset

The internal baby monitor feature is only available between handsets in the same radio cell.

- 1 **[Menu]** (right soft key) **#268**
- 2 **[↕]**: “On” → **[Select]**
- 3 **[↕]**: Select the desired handset number to monitor with. → **[Save]**
 - “Baby monitor” will be displayed.
 - The registered handset name/number is displayed.

Note:

- When this feature is on, another handset can hear the monitored handset by making an intercom call.

To monitor from an outside line

■ From the phonebook:

- 1 **[Menu]** (right soft key) **#268**
- 2 **[↕]**: “On” → **[Select]**

- 3 [↕]: Select "External" to monitor from an outside line. → [Edit] → [Add]
- 4 [↕]: "Phonebook" → [Select]
- 5 [↕]: Select the phonebook entry. → [Select]
- 6 [↕]: Select the desired phone number. → [Save]
 - "Baby monitor" will be displayed.

Note:

- If you edit a phonebook entry which is assigned for monitoring, the edited entry does not transfer to the monitor.

■ **By entering phone numbers:**

- 1 [Menu] (right soft key) [#][2][6][8]
- 2 [↕]: "On" → [Select]
- 3 [↕]: Select "External" to monitor from an outside line. → [Edit] → [Add]
- 4 [↕]: "Manual" → [Select]
- 5 Enter the desired name. → [OK]
- 6 Enter the desired number. → [OK] → [Select]
 - "Baby monitor" will be displayed.

Note:

- The registered name/number is displayed.

Turning off the baby monitor

The monitored handset cannot be used while baby monitor is set to "On".

- 1 Press [Menu] on the handset being monitored.
- 2 [↕]: "On/Off" → [Select]
- 3 [↕]: "Off" → [Select] → [OFF]

Editing an outside monitoring number

- 1 Press [Menu] on the handset being monitored.
- 2 [↕]: "On/Off" → [Select]
- 3 [↕]: "On" → [Select]
- 4 [↕]: Select the outside line. → [Edit]

- 5 [Menu] → [↕]: "Edit" → [Select]
- 6 Edit the name if necessary. → [OK]
- 7 Edit the phone number if necessary. → [OK] → [Select]

Erasing an outside monitoring number

- 1 Press [Menu] on the handset being monitored.
- 2 [↕]: "On/Off" → [Select]
- 3 [↕]: "On" → [Select]
- 4 [↕]: Select the outside line. → [Edit]
- 5 [Menu] → [↕]: "Erase" → [Select]
- 6 [↕]: "Yes" → [Select] → [OFF]

Baby monitor sensitivity

You can adjust the sensitivity of the baby monitor. Increase or decrease the sensitivity to adjust the sound level needed to trigger the baby monitor feature.

- This feature cannot be set during a monitoring call.
- 1 Press [Menu] on the handset being monitored.
 - 2 [↕]: "Sensitivity level" → [Select]
 - 3 [↕]: Select the desired setting. → [Save] → [OFF]

Answering the baby monitor

■ **When monitoring with a handset:**

Press [↶] to answer calls.

If you want to respond from the monitoring handset, press [Mute].

- The monitoring handset will answer calls automatically when the auto intercom feature is set to "On" (page 15).

Note:

- If you receive an outside call when communicating with the monitored handset, you hear 2 tones. To answer the call, press [OFF], then press [↶].

Programming

■ When monitoring from an outside line:

To answer a call, follow the operation for your phone.

If you want to respond from the monitoring handset, press **[#][1]** using tone dialing.

You can turn off the baby monitor feature by pressing **[#][0]**.

Note:

- 2 minutes after the monitored handset starts a call, communication between the monitored handset and monitoring phone line is turned off automatically.

Other programming

Changing the handset name

Each handset can be given a customized name ("Bob", "Kitchen", etc.). This is useful when you make intercom calls between handsets. You can also select whether or not the handset name is displayed in standby mode. The default setting is "No". If you select "Yes" without entering any handset name, "Handset 1" to "Handset 6" is displayed.

- 1 **[Menu]** (right soft key) **[#][1][0][4]**
- 2 Enter the desired name (max. 10 characters).
- 3 **[Save]**
- 4 **[↕]**: Select the desired setting. → **[Select]** 2 times → **[OFF]**

Calendar/Schedule

You can program 20 schedule alarms for each handset using the calendar. A schedule alarm sounds at the set time for 1 minute. A text memo can also be displayed for the schedule alarm.

Important:

- Make sure the unit's date and time setting is correct (page 11).

Adding a new entry

- 1 **[Menu]** (right soft key) → **[☰]** → **[Select]**
- 2 **[↕]**: Select the desired date. → **[Select]**
- 3 **[Menu]** → **[↕]**: "Add new entry" → **[Select]**
- 4 Edit the date if necessary. → **[OK]**
- 5 Set the desired time. → **[OK]**
- 6 Enter a text memo (30 characters max.; page 16). → **[OK]**
- 7 **[↕]**: Select the desired alarm tone. → **[Select]** 2 times
 - You can select "off" if you prefer not to hear an alarm tone.
 - We recommend selecting a different ringer tone from the one used for outside calls.
- 8 **[OFF]**

Note:

- To stop the alarm, press **[Stop]** or place the handset on the base unit or charger.
- When the handset is in use, the alarm will not sound until the handset is in standby mode.

Viewing entries

- 1 **[Menu]** (right soft key) → **[☰]** → **[Select]**
- 2 To see the entries on the selected date, press **[Select]**.
To see the schedule list, press **[List]**.
 - You can see detailed information about the schedule by pressing **[Menu]**. → **[↕]**: "Detail" → **[Select]**

Editing an entry

- 1 **[Menu]** (right soft key) → **[☰]** → **[Select]**
- 2 **[List]** → **[↕]**: Select the desired entry.
- 3 **[Menu]** → **[↕]**: "Edit" → **[Select]**
- 4 Edit the date if necessary. → **[OK]**
- 5 Edit the time if necessary. → **[OK]**

- 6 Edit the text memo if necessary (30 characters max.). → [OK]
- 7 [↕]: Select the desired alarm tone. → [Select] 2 times → [OFF]

Erasing an entry

Schedule alarm entries are not erased automatically after the schedule alarm sounds. Erase unwanted entries.

- 1 [Menu] (right soft key) →  → [Select]
- 2 [List] → [↕]: Select the desired entry.
- 3 [Menu] → [↕]: "Erase" → [Select]
- 4 [↕]: "Yes" → [Select] → [OFF]

Erasing all entries

- 1 [Menu] (right soft key) →  → [Select]
- 2 [List] → [Menu]
- 3 [↕]: "Erase all" → [Select]
- 4 [↕]: "Yes" → [Select]
- 5 [↕]: "Yes" → [Select] → [OFF]

Registering a unit

Operating additional units

Additional handsets

Up to 6 handsets can be registered to the base unit.





Important:

- The additional handset model recommended for use with this unit is noted on page 4. If another handset model is used, certain operations may not be available.

Registering a handset to the base unit





The supplied handset and base unit are pre-registered. If for some reason the handset

is not registered to the base unit (for example,  is displayed even when the handset is near the base unit), re-register the handset.

- 1 **Handset:**
[Menu] (right soft key)    
- 2 **Base unit:**
Press and hold [•••] for about 5 seconds.
 - If all registered handsets start ringing, press [•••] again to stop, then repeat this step.
- 3 **Handset:**
Press [OK], then wait until a long beep sounds.

Deregistering a handset

A handset can cancel its own registration to the base unit, or other handsets registered to the same base unit. This allows the handset to end its wireless connection with the system.

- 1 [Menu] (right soft key)    
 - All handsets registered to the base unit are displayed.
- 2 [↕]: Select the handset you want to cancel. → [Select]
- 3 [↕]: "Yes" → [Select]
- 4 [OFF]

Call Display Service

Using Call Display service

Important:

- This unit is Call Display compatible. To use Call Display features, you must subscribe to a Call Display service. Contact your service provider/telephone company for details.

Call Display features

When an outside call is being received, the caller information is displayed. Caller information for the last 50 callers is logged in the caller list from the most recent call to the oldest.

- If the unit cannot receive caller information, the following is displayed:
 - “**Unavailable Name & No.**”: The caller dials from an area which does not provide a Call Display service.
 - “**Private caller**”: The caller requests not to send caller information.
 - “**Long distance**”: The caller makes a long distance call.
- If the unit is connected to a PBX system, caller information may not be properly received. Contact your PBX supplier.

Missed calls

If a call is not answered, the unit treats it as a missed call and “**Missed call**” is displayed. This lets you know if you should view the caller list to see who called while you were away.

Even if only one missed call in the caller list is viewed (page 34), “**Missed call**” disappears from the display. When you receive another new call, “**Missed call**” is displayed again.

Note:

- Even when there are unviewed missed calls, “**Missed call**” disappears from the standby display if the following operation is performed by one of the registered handsets:
 - Being replaced on the base unit or charger.

- Pressing **[OFF]**.

Phonebook name display

When caller information is received and it matches a phone number stored in the phonebook, the stored name in the phonebook is displayed and logged in the caller list.

Talking Call Display

This feature lets you know who is calling without looking at the display.

To use this feature, you must:

- subscribe to a Call Display service of your service provider/telephone company.
- turn this feature on (page 22).

When caller information is received, the handsets announce the caller’s name or phone number received from your service provider/telephone company following every ring.

- Name pronunciation may vary. This feature may not pronounce all names correctly.
- Call Display service has a limit of how many characters can be displayed. If the caller’s name is too long, the unit may not be able to display or announce the entire name.

Phonebook name announcement

When caller information is received and it matches a phone number stored in the phonebook, the stored name in the phonebook is announced.

For Call Waiting Deluxe service users

To use Call Waiting Deluxe, you must subscribe to Call Waiting Deluxe from your service provider/telephone company. This feature not only allows the unit currently in use to display the 2nd caller’s information, but also offers you a variety of ways to deal with the 2nd call.

Call Display Service

Important:

- Please contact your service provider/ telephone company for details and availability of this service in your area.
- This feature must be turned on before it can be used.

To turn Call Waiting Deluxe on/off

To use Call Waiting Deluxe, you must turn this feature on. The default setting is "OFF".

- 1 **[Menu]** (right soft key) **[#][2][1][5]**
- 2 **[↕]**: Select the desired setting.
- 3 **[Save]**→ **[OFF]**

Call Waiting Deluxe service options

When a 2nd call is received, you can choose how to handle the call by selecting an option shown on the unit display.

Note:

- Your service provider/telephone company may not offer all of the options (page 33).

| Displayed option | Function |
|------------------|---|
| Answer | Answers the waiting call, while keeping the 1st call on hold. |
| Hold | Holds the waiting call. The caller will hear the pre-recorded hold message played by your service provider/ telephone company. |
| Announce | The caller will hear the pre-recorded busy message played by your service provider/ telephone company (for example, "We are not available now.") and will then be disconnected. |

| Displayed option | Function |
|---------------------|---|
| Forward | Forwards the waiting call to the Voice Mail service provided by your service provider/telephone company. You must subscribe to Voice Mail service to use this function. |
| Drop | Disconnects (drops) the current call and answers the waiting call. |
| Conference | Answers the waiting call and combines it with the current call to make a conference call (3-party call). |
| Return | Returns to the waiting caller while keeping the current call on hold. |
| Drop caller1 | Disconnects (drops) the 1st call during a conference call. |
| Drop caller2 | Disconnects (drops) the 2nd call during a conference call. |

To use Call Waiting Deluxe service

- 1 When you hear a Call Waiting tone during an outside call, press **[FLASH]**.
 - The option menu is displayed.
- 2 **[↕]**: Select the desired option. → **[Select]**
 - After selecting "Answer", "Hold", or "Conference", you can select another option. → **[FLASH]** → **[↕]**: Select the desired option. → **[Select]**

Note:

- To exit from the option menu, wait for 20 seconds.

Call Display Service

Caller list

Important:

- Make sure the unit's date and time setting is correct (page 11).

Viewing the caller list and calling back

- 1 **[▼]** CID
- 2 Press **[▼]** to search from the most recent call, or press **[▲]** to search from the oldest call.
 - You can see the detailed information about the caller by pressing **[Detail]** when in multiple display mode.
- 3 To call back, press **[↶]**.
To exit, press **[OFF]**.

Note:

- If the entry has already been viewed or answered, "✓" is displayed.

Editing a caller's phone number

You can edit a phone number in the caller list by adding the long distance code "1" or removing its area code.

- 1 **[▼]** CID
- 2 **[↕]**: Select the desired entry. → **[Detail]**
- 3 **[Menu]** → **[↕]**: "Edit" → **[Select]**
- 4 Press **[Edit]** repeatedly until the phone number is shown in the desired format.
- 5 **[↶]**

Note:

- The number edited in step 4 will not be saved in the caller list.

Erasing selected caller information

- 1 **[▼]** CID
- 2 **[↕]**: Select the desired entry.
- 3 **[Erase]** → **[↕]**: "Yes" → **[Select]** → **[OFF]**

Erasing all caller information

- 1 **[▼]** CID
- 2 **[Erase]** → **[↕]**: "Yes" → **[Select]** → **[OFF]**

Answering system

The answering system can answer and record calls for you when you are unavailable to answer the phone.

You can also set the unit to play a greeting message but not to record caller messages by selecting “**Greeting only**” as the recording time setting (page 40).

Important:

- Make sure the unit’s date and time setting is correct (page 11).

Memory capacity (including your greeting message)

The total recording capacity is about 37 minutes. A maximum of 64 messages can be recorded.

Note:

- When message memory becomes full:
 - “**Messages full**” is shown on the handset display.
 - If you use the pre-recorded greeting message, the unit automatically switches to another pre-recorded greeting message asking callers to call again later.
 - If you recorded your own greeting message, the same message is still announced to callers even though their messages are not recorded.

Turning the answering system on/off

The answering system is preset to on.

- To turn on:**
[Menu] (right soft key) **#327**
To turn off:
[Menu] (right soft key) **#328**
- [OFF]**

Note:

- When the answering system is turned on, **00** is displayed.

Greeting message

When the unit answers a call, a greeting message is played to callers.

You can use either:

- your own greeting message
- a pre-recorded greeting message

Recording your greeting message

- [Menu]** (right soft key) **#302**
- [↕]: “yes” → [Select]**
- After a beep sounds, hold the handset about 20 cm (8 inches) away and speak clearly into the microphone (2 minutes max.).
- Press **[Stop]** to stop recording. → **[OFF]**

Using a pre-recorded greeting message

The unit provides 2 pre-recorded greeting messages:

- If you erase or do not record your own greeting message, the unit plays a pre-recorded greeting asking callers to leave a message.
- If the message recording time (page 40) is set to “**Greeting only**”, callers’ messages are not recorded and the unit plays a different pre-recorded greeting message asking callers to call again.

Resetting to a pre-recorded greeting message

If you want to use a pre-recorded greeting message once you record your own greeting message, you need to erase your own greeting message.

- [Menu]** (right soft key) **#304**
- [Yes] → [OFF]**

Answering System

Playing back the greeting message

- 1 **[Menu]** (right soft key) **# 3 0 3**
- 2 To exit, press **[OFF]**.

Listening to messages

When new messages have been recorded, “**New message**” is displayed on the handset.

- 1 **To listen to new messages:**
[Play]*1
or
[Menu] (right soft key) **# 3 2 3**
To listen to all messages:
[Menu] (right soft key) **# 3 2 4**

- 2 When finished, press **[OFF]**

*1 If there are no new messages in the answering system, **[Play]** is not displayed.

Note:

- To switch to the receiver, press **[↶]**.

Listening to messages from the message list

You can select the item to play back.

- 1 **[Menu]** (right soft key) **# 3 2 9**
- 2 **[↕]**: Select the desired item from the message list. → **[Play]**
 - You can erase the selected message as follows:
[Menu] → **[↕]**: “**Erase**” → **[Select]**
→ **[↕]**: “**Yes**” → **[Select]**
- 3 When finished, press **[OFF]**

Note:

- If the item has already been heard, “**✓**” is displayed, even if it was heard using another handset.
- “**Message**” is displayed in the message list if the unit cannot receive caller information.

Operating the answering system

[Menu] (right soft key) → **☰** → **[Select]**

| Key | Operation |
|---------------------------|---|
| [▲] or [▼] | Adjust the receiver or speaker volume (during playback) |
| 1 or [◀] | Repeat message (during playback)*1 |
| 2 or [▶] | Skip message (during playback)*2 |
| 3 | Enter the “ Settings ” menu |
| 4 | Play new messages |
| 5 | Play all messages |
| 6 | Play greeting message |
| 7/6 | Record greeting message |
| 8 | Turn answering system on |
| [Pause] | Pause message*3 |
| 9 or [Stop] | Stop recording Stop playback |
| 0 | Turn answering system off |
| [X] 4 *4 | Erase currently playing message |
| [X] 5 | Erase all messages |
| [X] 6 | Reset to a pre-recorded greeting message |

*1 If pressed within the first 5 seconds of a message, the previous message is played except when playing back from the message list.

*2 When you play a message from the message list, the unit stops message playback and the display goes back to the message list.

*3 To resume playback:
[↕]: “**Playback**” → **[Select]**

*4 You can also erase as follows:
[Pause] → **[↕]**: “**Erase**” → **[Select]**
→ **[↕]**: “**Yes**” → **[Select]**

Rewinding the message

Press and hold **[◀]** until the unit plays the desired part of the message.

- During rewinding, the handset makes a continuous beeping sound. Rewinding speed may vary depending on the recorded message.
- At the beginning of the message, the unit plays the message at normal speed.

Fast-forwarding the message

Press and hold **[▶]** until the unit plays the desired part of the message.

- During fast-forwarding, the handset makes a continuous beeping sound. Fast-forwarding speed may vary depending on the recorded message.
- Even if you press and hold **[▶]** when the end of this message is played, the next message is played at normal speed.

Calling back (Call Display subscribers only)

- 1 Press **[Pause]** during playback.
- 2 **[↕]**: "Call back" → **[Select]**

Editing the number before calling back

- 1 Press **[Pause]** during playback.
- 2 **[↕]**: "Edit & Call" → **[Select]**
- 3 Press **[Edit]** repeatedly until the phone number is shown in the desired format (page 34). → **[↶]**

Erasing all messages

- 1 **[Menu]** (right soft key) **#3325**
- 2 **[↕]**: "Yes" → **[Select]** → **[OFF]**

Advanced new message alerting features

Audible message alert

This feature allows the handset to beep to inform you of a new message arrival when new messages are recorded. The handset

beeps 2 times every minute until you listen to the messages, if the "Handset beep" setting is turned on. The default setting is "OFF".

- 1 **[Menu]** (right soft key) **#339**
- 2 **[↕]**: Select the desired setting. → **[Save]** → **[OFF]**

New message alert by a call

This feature allows you to receive a notification by phone when new messages are recorded. The base unit calls a phone number you specify. You can then operate the answering system remotely to listen to the new message.

To use this feature, you must:

- store a phone number to which the unit makes the call to.
 - turn on the new message alert setting.
- After you answer the new message alert call, you can listen to messages from that call (page 38).

Important:

- A new message alert is stopped 1 minute after the unit starts to call. The unit will not retry the call even if the call is not answered.

Storing a phone number to which the unit makes an alert call

■ From the phonebook:

- 1 **[Menu]** (right soft key) **#338**
- 2 **[↕]**: "Notification to" → **[Select]** → **[Add]**
- 3 **[↕]**: "Phonebook" → **[Select]**
- 4 **[↕]**: Select the desired phonebook entry. → **[Select]**
- 5 **[↕]**: Select the desired phone number. → **[Save]** → **[OFF]**

■ By entering a phone number:

- 1 **[Menu]** (right soft key) **#338**
- 2 **[↕]**: "Notification to" → **[Select]** → **[Add]**
- 3 **[↕]**: "Manual" → **[Select]**

Answering System

- 4 Enter the desired name (16 characters max.). → [OK]
- 5 Enter the desired number (24 digits max.). → [OK] → [Select] → [OFF]

Turning on/off the new message alert setting

- 1 [Menu] (right soft key) [#] [3] [3] [8]
- 2 [↕]: "On/Off" → [Select]
- 3 [↕]: Select the desired setting. → [Save] → [OFF]

Editing the set phone number

- 1 [Menu] (right soft key) [#] [3] [3] [8]
- 2 [↕]: "Notification to" → [Select]
- 3 [Menu] → [↕]: "Edit" → [Select]
- 4 Edit the name if necessary (16 characters max.). → [OK]
- 5 Edit the phone number if necessary (24 digits max.). → [OK] → [Select] → [OFF]

Erasing the set phone number

- 1 [Menu] (right soft key) [#] [3] [3] [8]
- 2 [↕]: "Notification to" → [Select]
- 3 [Menu] → [↕]: "Erase" → [Select]
- 4 [↕]: "Yes" → [Select] → [OFF]
 - The new message alert setting is turned off.

Activating/inactivating the remote access code to play messages

If you activate this feature, you must enter the remote access code (page 38) to play the new message from the new message alert call. This is so that unauthorized parties cannot listen to your messages. The default setting is "Inactivate".

- "Inactivate": You can listen to the message by pressing [4] to play new messages (without entering the remote access code).

- "Activate": You must enter your remote access code (page 38) and then press [4] to play new message.

- 1 [Menu] (right soft key) [#] [3] [3] [8]
- 2 [↕]: "Remote code" → [Select]
- 3 [↕]: "Activate" or "Inactivate" → [Save] → [OFF]

Listening to messages

After you answer the new message alert, you can listen to the messages as follows.

■ When the remote access code is set to "Inactivate":

Press [4] to play the new message during the announcement.

■ When the remote access code is set to "Activate":

- 1 Enter the remote access code (page 38) during the announcement.
- 2 Press [4] to play the new message.

Note:

- Within 10 seconds after listening to new messages, you can press [#] [9] during the call to turn off the new message alert by a call feature.
- Even if the unit makes a new message alert call, the handset redial list does not show the record.

Remote operation

Using a touch-tone phone, you can call your phone number from outside and access the unit to listen to messages or change answering system settings. The unit's voice guidance prompts you to press certain dial keys to perform different operations.

Remote access code

A 3-digit remote access code must be entered when operating the answering system remotely. This code prevents unauthorized parties from listening to your messages remotely. The default setting is "111".

Answering System

Important:

- To prevent unauthorized access to this product, we recommend that you regularly change the remote code.

- [Menu]** (right soft key) **#306**
- Enter the desired 3-digit remote access code.
- [Save]** → **[OFF]**

Deactivating remote operation

Press ***** in step 2 on "Remote access code", page 38.

- The entered remote access code is deleted.

Using the answering system remotely

- Dial your phone number from a touch-tone phone.
- After the greeting message starts, enter your remote access code.
- Follow the voice guidance prompts as necessary or control the unit using remote commands (page 39).
- When finished, hang up.

Voice guidance

During remote operation, the unit's voice guidance starts and prompts you to press **1** to perform a specific operation, or press **2** to listen to more available operations.

Note:

- If you do not press any dial keys within 10 seconds after a voice guidance prompt, the unit disconnects your call.

Remote commands

You can press dial keys to access certain answering system functions without waiting for the voice guidance to prompt you.

| Key | Operation |
|----------|------------------------------------|
| 1 | Repeat message (during playback)*1 |

| Key | Operation |
|-----------|-----------------------------------|
| 2 | Skip message (during playback) |
| 4 | Play new messages |
| 5 | Play all messages |
| 9 | Stop playback |
| 0 | Turn answering system off |
| *4 | Erase currently playing message |
| *5 | Erase all messages |
| *# | End remote operation (or hang up) |

*1 If pressed within the first 5 seconds of a message, the previous message is played.

Turning on the answering system remotely

- Dial your phone number from a touch-tone phone.
- Let the phone ring 15 times.
 - A long beep is heard.
- Enter your remote access code within 10 seconds after the long beep.
 - The greeting message is played back.
 - You can either hang up, or enter your remote access code again and begin remote operation (page 38).

Answering system settings

Call screening

While a caller is leaving a message, you can listen to the call through the handset's speaker. To adjust the speaker volume, press **[▲]** or **[▼]** repeatedly. You can answer the call by pressing **[↶]** on the handset. Call screening can be set for each handset. The default setting is "on".

- [Menu]** (right soft key) **#310**
- [↕]**: Select the desired setting. → **[Save]** → **[OFF]**

Answering System

Number of rings before the unit answers a call

You can change the number of times the phone rings “**Ring count**” before the unit answers calls. You can select 2 to 7 rings, or “**Toll saver**”.

The default setting is “**4 rings**”.

“**Toll saver**”: The unit’s answering system answers at the end of the 2nd ring when new messages have been recorded, or at the end of the 5th ring when there are no new messages. If you call your phone from outside to listen to new messages (page 39), you know that there are no new messages when the phone rings for the 3rd time. You can then hang up without being charged for the call.

- 1 **[Menu]** (right soft key) **#** **2** **1** **1**
- 2 **[↓]**: Select the desired setting. → **[Save]** → **[OFF]**

For Voice Mail service subscribers

If you subscribe to a flat-rate service package that includes Call Display, Call Waiting, Voice Mail, and unlimited local/regional/long distance calls, please note the following:

- To use the Voice Mail service provided by your service provider/telephone company rather than the unit’s answering system, turn off the answering system (page 35).
- To use this unit’s answering system rather than the Voice Mail service provided by your service provider/telephone company, please contact your service provider/telephone company to deactivate your Voice Mail service.

If your service provider/telephone company cannot do this:

- Set this unit’s “**Ring count**” setting so that this unit’s answering system answers calls before the Voice Mail service of your service provider/telephone company does. It is necessary to check the number of rings required to activate the Voice Mail service provided by your service provider/telephone company before changing this setting.
- Change the number of rings of the Voice Mail service so that the answering

system can answer the call first. To do so, contact your service provider/telephone company.

Caller’s recording time

You can change the maximum message recording time allowed for each caller. The default setting is “**3 min**”.

- 1 **[Menu]** (right soft key) **#** **3** **0** **5**
- 2 **[↓]**: Select the desired setting. → **[Save]** → **[OFF]**

Selecting “Greeting only”

You can select “**Greeting only**” which sets the unit to announce a greeting message to callers but not record messages.

Select “**Greeting only**” in step 2 on “**Caller’s recording time**”, page 40.

Note:

- When you select “**Greeting only**”:
 - If you do not record your own message, the unit will play the pre-recorded greeting-only message asking callers to call again later.
 - If you use your own message, record the greeting-only message asking callers to call again later (page 35).

Voice Mail service

Voice Mail is an automatic answering service offered by your service provider/telephone company. After you subscribe to this service, your service provider/telephone company's Voice Mail system answers calls for you when you are unavailable to answer the phone or when your line is busy. Messages are recorded by your service provider/telephone company, not your telephone. Please contact your service provider/telephone company for details of this service.

Important:

- To use the Voice Mail service provided by your service provider/telephone company rather than the unit's answering system, turn off the answering system (page 35). For details, see page 40.

Storing the Voice Mail (VM) access number

In order to listen to your Voice Mail messages, you must dial your service provider/telephone company's Voice Mail access number. Once you have stored your Voice Mail access number, you can dial it automatically (page 41).

- 1 **[Menu]** (right soft key) **#3331**
- 2 Enter your access number (24 digits max.). → **[Save]** → **[OFF]**

Note:

- When storing your Voice Mail access number and your mailbox password, press **[▲]** (Pause) to add pauses (page 13) between the access number and the password as necessary. Contact your service provider/telephone company for the required pause time.

Example:

| | | |
|----------------|--------|----------|
| 1-222-333-4444 | PPPP | 8888 |
| | | |
| VM access | Pauses | Password |
| number | | |

To erase the Voice Mail access number

- 1 **[Menu]** (right soft key) **#3331**
- 2 Press and hold **[Clear]** until all digits are erased. → **[Save]** → **[OFF]**

Voice Mail (VM) tone detection

Your service provider/telephone company sends special signals (sometimes called "Voice Mail tones" or "stutter tones") to the unit to let you know you have new Voice Mail messages. If you hear a series of dial tones followed by a continuous dial tone after you press **[↶]**, you have new Voice Mail messages. Soon after you hang up a call or after the phone stops ringing, your unit checks the phone line to see if new Voice Mail messages have been recorded.

Turn this feature off when:

- You do not subscribe to Voice Mail service.
- Your service provider/telephone company does not send Voice Mail tones.
- Your phone is connected to a PBX.

If you are not sure which setting is required, contact your service provider/telephone company.

Turning VM tone detection on/off

The default setting is "On".

- 1 **[Menu]** (right soft key) **#3332**
- 2 **[↕]**: Select the desired setting. → **[Save]** → **[OFF]**

Listening to Voice Mail messages

The unit lets you know that you have new Voice Mail messages in the following way:

- "New Voice Mail" is displayed if message indication service is available.

- 1 **[VM]*1**
or
[Menu] (right soft key) **#3330**
 - The speakerphone turns on.
- 2 Follow the pre-recorded instructions.
- 3 When finished, press **[OFF]**.

Useful Information

*1 If there are no new messages in the Voice Mail, **[VM]** is not displayed.

all new messages, turn it off by pressing and holding **[#]** until the handset beeps.

Note:

- If the handset still indicate there are new messages even after you have listened to

Error messages

| Display message | Cause/solution |
|---|---|
| Ask phone company for VM access # | <ul style="list-style-type: none"> ● You have not stored the Voice Mail access number. Store the number (page 41). |
| Base no power or No link to base. Reconnect main base AC adaptor. | <ul style="list-style-type: none"> ● The handset has lost communication with the base unit. Move closer to the base unit and try again. ● Unplug the base unit's AC adaptor to reset the unit. Reconnect the adaptor and try again. ● The handset's registration may have been cancelled. Re-register the handset (page 31). |
| Busy | <ul style="list-style-type: none"> ● The called unit is in use. ● Other units are in use and the system is busy. Try again later. ● The handset you are using is too far from the base unit. Move closer and try again. |
| Check tel line | <ul style="list-style-type: none"> ● The supplied telephone line cord has not been connected yet or not connected properly. Check the connections (page 8). |
| Error!! | <ul style="list-style-type: none"> ● Recording was too short. Try again. |
| Invalid | <ul style="list-style-type: none"> ● There is no handset registered to the base unit matching the handset number you entered. ● The handset is not registered to the base unit. Register the handset (page 31). |
| Memory full | <ul style="list-style-type: none"> ● The phonebook memory is full. Erase unwanted entries (page 17). ● Message memory is full. Erase unwanted messages (page 36). ● The call block list memory is full. Erase unwanted entries (page 28). ● The schedule alarm memory is full. Erase unwanted entries (page 31). |
| Requires subscription to Caller ID. | <ul style="list-style-type: none"> ● You must subscribe to a Call Display service. Once you receive caller information after subscribing to a Call Display service, this message will not be displayed. |
| Use rechargeable battery. | <ul style="list-style-type: none"> ● A wrong type of battery such as Alkaline or Manganese was inserted. Use only the rechargeable Ni-MH batteries noted on page 3, 6. |

Troubleshooting

If you still have difficulties after following the instructions in this section, disconnect the base unit's AC adaptor, then reconnect the base unit's AC adaptor. Remove the batteries from the handset, and then insert the batteries into the handset again.

General use

| Problem | Cause/solution |
|---|---|
| The handset does not turn on even after installing charged batteries. | <ul style="list-style-type: none"> Place the handset on the base unit or charger to turn on the handset. |
| The unit does not work. | <ul style="list-style-type: none"> Make sure the batteries are installed correctly (page 8). Fully charge the batteries (page 9). Check the connections (page 8). Unplug the base unit's AC adaptor to reset the unit. Reconnect the adaptor and try again. The handset has not been registered to the base unit. Register the handset (page 31). |
| The handset display is blank or dark. | <ul style="list-style-type: none"> The handset is in screen saver mode (page 12). Activate the handset display again by: <ul style="list-style-type: none"> pressing [OK] when on a call. pressing [OFF] at all other times. "LCD backlight" is set to "OFF" while on charge. Change the setting (page 23). |
| I cannot hear a dial tone. | <ul style="list-style-type: none"> Make sure that you are using the supplied telephone line cord. Your old telephone line cord may have a different wiring configuration. The base unit's AC adaptor or telephone line cord is not connected. Check the connections. Disconnect the base unit from the telephone line and connect the line to a known working telephone. If the working telephone operates properly, contact our service personnel to have the unit repaired. If the working telephone does not operate properly, contact your service provider/telephone company. |
| The handset beeps. | <ul style="list-style-type: none"> New messages have been recorded. Listen to the new messages (page 36). |
| The handset display begins operating automatically. | <ul style="list-style-type: none"> Demonstration mode is activated. Remove the batteries from the handset, and then insert the batteries into the handset again. |



Menu list

| Problem | Cause/solution |
|---|--|
| The display is in a language I cannot read. | <ul style="list-style-type: none"> Change the display language (page 11). |

Useful Information

| Problem | Cause/solution |
|---|---|
| I cannot display the wallpaper. | <ul style="list-style-type: none"> Wallpaper is displayed in the standby mode only when you select "Digital (Small)" or "Off" for the clock setting. Change the clock setting (page 23). |
| I cannot register a handset to a base unit. | <ul style="list-style-type: none"> The maximum number of handsets (6) is already registered to the base unit. Cancel unused handset registrations from the base unit (page 31). |

Battery recharge

| Problem | Cause/solution |
|--|--|
| The handset beeps and/or  flashes. | <ul style="list-style-type: none"> Battery charge is low. Fully charge the batteries (page 9). |
| I fully charged the batteries, but <ul style="list-style-type: none">  still flashes,  is displayed, or the operating time seems to be shorter. | <ul style="list-style-type: none"> Clean the battery ends (\oplus, \ominus) and the charge contacts with a dry cloth and charge again. It is time to replace the batteries (page 8). |

Making/answering calls, intercom

| Problem | Cause/solution |
|---|---|
|  is displayed. | <ul style="list-style-type: none"> The handset is too far from the base unit. Move closer. The base unit's AC adaptor is not properly connected. Reconnect AC adaptor to the base unit. The handset is not registered to the base unit. Register it (page 31). |
| Noise is heard, sound cuts in and out. | <ul style="list-style-type: none"> You are using the handset or base unit in an area with high electrical interference. Re-position the base unit and use the handset away from sources of interference. Move closer to the base unit. If you use a DSL/ADSL service, we recommend connecting a DSL/ADSL filter between the base unit and the telephone line jack. Contact your DSL/ADSL provider for details. |
| The handset does not ring. | <ul style="list-style-type: none"> The ringer volume is turned off. Adjust ringer volume (page 13, 22). Night mode is turned on. Turn it off (page 27). |
| I cannot make a call. | <ul style="list-style-type: none"> The dialing mode may be set incorrectly. Change the setting (page 12). |
| I cannot make long distance calls. | <ul style="list-style-type: none"> Make sure that you have long distance service. |

Useful Information

Call Display/Talking Call Display

| Problem | Cause/solution |
|--|--|
| Caller information is not displayed. | <ul style="list-style-type: none">• You must subscribe to a Call Display service. Contact your service provider/telephone company for details.• If your unit is connected to any additional telephone equipment such as a Call Display box or cordless telephone line jack, plug the unit directly into the wall jack.• If you use a DSL/ADSL service, we recommend connecting a DSL/ADSL filter between the base unit and the telephone line jack. Contact your DSL/ADSL provider for details.• The name display service may not be available in some areas. Contact your service provider/telephone company for details.• Other telephone equipment may be interfering with this unit. Disconnect the other equipment and try again. |
| Caller information is displayed or announced late. | <ul style="list-style-type: none">• Depending on your service provider/telephone company, the unit may display or announce the caller's information at the 2nd ring or later.• Move closer to the base unit. |
| Caller information is not announced. | <ul style="list-style-type: none">• The handset ringer volume is turned off. Adjust it (page 13, 22).• The Talking Call Display feature is turned off. Turn it on (page 22).• The number of rings for the answering system is set to "2 rings" or "Toll saver". Select a different setting (page 40). |
| I cannot dial the phone number edited in the caller list. | <ul style="list-style-type: none">• The phone number you dialed might have been edited incorrectly (for example, the long distance "1" or the area code is missing). Edit the phone number with another pattern (page 34). |
| Time on the unit has shifted. | <ul style="list-style-type: none">• Incorrect time information from incoming Call Display changes the time. Set the time adjustment to "Manual" (off) (page 22). |
| The 2nd caller's information is not displayed during an outside call. (Visual Call Waiting feature does not function.) | <ul style="list-style-type: none">• In order to use Call Display, Call Waiting, or Visual Call Waiting, you must first contact your service provider/telephone company and subscribe to the desired service. After subscribing, you may need to contact your service provider/telephone company again to activate this specific service, even if you already subscribed to both Call Display and Visual Call Waiting services. |

Useful Information

Answering system

| Problem | Cause/solution |
|---|---|
| The unit does not record new messages. | <ul style="list-style-type: none">• The answering system is turned off. Turn it on (page 35).• The message memory is full. Erase unwanted messages (page 37).• The recording time is set to “Greeting only”. Change the setting (page 40).• If you subscribe to a Voice Mail service, messages are recorded by your service provider/telephone company, not your telephone. Change the unit’s number of rings setting or contact your service provider/telephone company (page 40). |
| I cannot operate the answering system remotely. | <ul style="list-style-type: none">• The remote access code is not set. Set the remote access code (page 38).• You are entering the wrong remote access code. If you have forgotten your remote access code, enter the remote access code setting to check your current code (page 38).• The answering system is turned off. Turn it on (page 39). |
| The unit does not emit the specified number of rings. | <ul style="list-style-type: none">• If the first ring is turned off, the number of rings decreases by 1 from the specified number of rings. |

Liquid damage

| Problem | Cause/solution |
|---|---|
| Liquid or other form of moisture has entered the handset/base unit. | <ul style="list-style-type: none">• Disconnect the AC adaptor and telephone line cord from the base unit. Remove the batteries from the handset and leave to dry for at least 3 days. After the handset/base unit are completely dry, reconnect the AC adaptor and telephone line cord. Insert the batteries and charge fully before use. If the unit does not work properly, contact an authorized service centre. |

Caution:

- To avoid permanent damage, do not use a microwave oven to speed up the drying process.

Industry Canada Notices and other information

NOTICE:

This equipment meets the applicable Industry Canada Terminal Equipment Technical Specifications. This is confirmed by the registration number. The abbreviation, "IC:", before the registration number signifies that registration was performed based on a Declaration of Conformity indicating that Industry Canada technical specifications were met. It does not imply that Industry Canada approved the equipment.

Users should ensure, for their own protection, that the electrical ground connections of the power utility, telephone lines and internal metallic water pipe system, if present, are connected together. This precaution may be particularly important in rural areas.

NOTICE:

The **Ringer Equivalence Number (REN)** assigned to each terminal device provides an indication of the maximum number of terminals allowed to be connected to a telephone interface. The termination on an interface may consist of any combination of devices subject only to the requirement that the sum of the Ringer Equivalence Numbers of all the devices does not exceed 5. The Ringer Equivalence Number (REN) of this unit:
(found on the bottom of the unit).

NOTICE:

Operation is subject to the following two conditions: (1) this device may not cause interference, and (2) this device must accept any interference, including interference that may cause undesired operation of the device.

Privacy of communications may not be ensured when using this telephone.

Some cordless telephones operate at frequencies that may cause interference to nearby TVs and VCRs. To minimize or prevent such interference, the base of the cordless telephone should not be placed

near, or on top of, a TV or VCR. If interference is experienced, move the cordless telephone further away from the TV or VCR. This will often reduce, or eliminate, interference.

RF Exposure Warning:

- This product complies with IC radiation exposure limits set forth for an uncontrolled environment.
- To comply with IC RF exposure requirements, the base unit must be installed and operated 20 cm (8 inches) or more between product and all person's body.
- This product may not be collocated or operated in conjunction with any other antenna or transmitter.
- For body-worn operation, the handset must be used only with a non-metallic accessory. Use of other accessories may not ensure compliance with IC RF exposure requirements.

Useful Information

Warranty

Panasonic Canada Inc.
5770 Ambler Drive, Mississauga, Ontario L4W 2T3
PANASONIC PRODUCT - LIMITED WARRANTY

EXCHANGE PROGRAM

Panasonic Canada Inc. warrants this product to be free from defects in material and workmanship under normal use and for a period as stated below from the date of original purchase agrees to, at its option either (a) repair your product with new or refurbished parts, (b) replace it with a new or a refurbished equivalent value product, or (c) refund your purchase price. The decision to repair, replace or refund will be made by Panasonic Canada Inc.

Telephone Accessory / Product

One (1) year

This warranty is given only to the original purchaser, or the person for whom it was purchased as a gift, of a Panasonic brand product mentioned above sold by an authorized Panasonic dealer in Canada and purchased and used in Canada, which product was not sold "as is", and which product was delivered to you in new condition in the original packaging.

IN ORDER TO BE ELIGIBLE TO RECEIVE WARRANTY SERVICE HEREUNDER, A PURCHASE RECEIPT OR OTHER PROOF OF DATE OF ORIGINAL PURCHASE, SHOWING AMOUNT PAID AND PLACE OF PURCHASE IS REQUIRED

LIMITATIONS AND EXCLUSIONS

This warranty **ONLY COVERS** failures due to defects in materials or workmanship, and **DOES NOT COVER** normal wear and tear or cosmetic damage. The warranty **ALSO DOES NOT COVER** damages which occurred in shipment, or failures which are caused by products not supplied by Panasonic Canada Inc., or failures which result from accidents, misuse, abuse, neglect, mishandling, misapplication, alteration, faulty installation, set-up adjustments, misadjustment of consumer controls, improper maintenance, improper batteries, power line surge, lightning damage, modification, introduction of sand, humidity or liquids, commercial use such as hotel, office, restaurant, or other business or rental use of the product, or service by anyone other than a Authorized Servicer, or damage that is attributable to acts of God.

Rechargeable batteries are warranted for ninety (90) days from date of original purchase.

THIS EXPRESS, LIMITED WARRANTY IS IN LIEU OF ALL OTHER WARRANTIES, EXPRESS OR IMPLIED, INCLUDING ANY IMPLIED WARRANTIES OF MERCHANTABILITY AND FITNESS FOR A PARTICULAR PURPOSE. IN NO EVENT WILL PANASONIC CANADA INC. BE LIABLE FOR ANY SPECIAL, INDIRECT OR CONSEQUENTIAL DAMAGES RESULTING FROM THE USE OF THIS PRODUCT OR ARISING OUT OF ANY BREACH OF ANY EXPRESS OR IMPLIED WARRANTY. (As examples, this warranty excludes damages for lost time, travel to and from the Authorized Servicer, loss of or damage to media or images, data or other memory or recorded content. This list of items is not exhaustive, but for illustration only.)

In certain instances, some jurisdictions do not allow the exclusion or limitation of incidental or consequential damages, or the exclusion of implied warranties, so the above limitations and exclusions may not be applicable. This warranty gives you specific legal rights and you may have other rights which vary depending on your province or territory.

CONTACT INFORMATION

For product information and operation assistance, please visit our support page on:

<http://panasonic.ca/english/support>
<http://panasonic.ca/french/support>

Index

- # 3-way conference: 14
- A** Additional handsets: 31
 - Alarm: 26
 - Answering calls: 13
 - Answering system: 35
 - Call screening: 39
 - Erasing messages: 36, 37, 39
 - Greeting message: 35
 - Greeting only: 40
 - Listening to messages: 36, 39
 - Message list: 36
 - New message alerting: 37
 - Number of rings: 40
 - Recording time: 40
 - Remote access code: 38
 - Remote operation: 38
 - Ring count: 40
 - Toll saver: 40
 - Turning on/off: 35
 - Auto intercom: 15
 - Auto talk: 13, 23
- B** Baby monitor: 28
 - Battery: 8, 9
 - Booster (Clarity booster): 14
- C** C.WTG (Call Waiting Deluxe): 42
 - Calendar: 30
 - Call block: 27
 - First ring: 28
 - Call Display service: 32
 - Call share: 14
 - Call Waiting: 14
 - Caller list: 34
 - Caller list edit: 34
 - Chain dial: 18
 - CID (Call Display): 34
 - Conference calls: 15
 - Control type: 10
 - Customer support: 24
- D** Date and time: 11
 - Dialing mode: 12
 - Direct command code: 20
 - Display
 - Clock: 23
 - Colour: 23
 - Contrast: 23
 - Display mode: 23
 - Language: 11
 - LCD backlight: 23
 - Wallpaper: 23
- E** Eco mode: 9
 - Equalizer: 14
 - Error messages: 42
- F** Flash: 14, 24
- G** Groups: 17
- H** Handset
 - Deregistration: 31
 - Name: 30
 - Registration: 31
 - Hold: 13
- I** Intercom: 15
- K** Key detector: 22, 25
 - Key tone: 23
- L** Line mode: 24
- M** Making calls: 13
 - Missed calls: 32
 - Mute: 13
- N** Night mode: 26
 - Noise reduction: 14
- P** Pause: 13
 - Phonebook: 16
 - Power failure: 9
 - Privacy mode: 24
- R** Redialing: 13
 - Ringer tone: 22
 - Rotary/pulse service: 14
- S** Schedule: 30
 - Speed dial: 18
 - SP-PHONE (Speakerphone): 13
- T** Talking Call Display: 22, 32
 - Temporary tone dialing: 14
 - Time adjustment: 22
 - Transferring calls: 15
 - Troubleshooting: 43
- V** Visual Call Waiting: 14
 - VM (Voice Mail): 41
 - Voice guidance language: 11
 - Voice Mail: 40, 41
 - Volume
 - Receiver: 13
 - Ringer (Handset): 13, 22
 - Speaker: 13

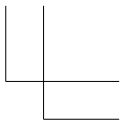
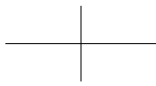
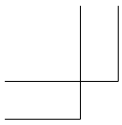

Notes

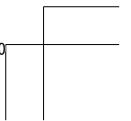
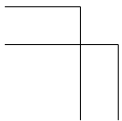
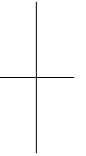
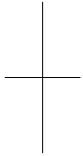

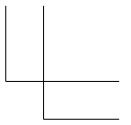
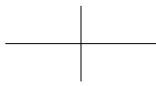
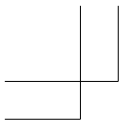

Notes

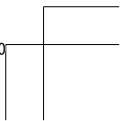
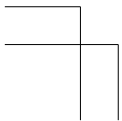
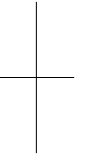
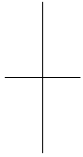

For your future reference

We recommend keeping a record of the following information to assist with any repair under warranty.

| | |
|--|------------------|
| Serial No. (found on the bottom of the base unit) | Date of purchase |
| Name and address of dealer | |

| |
|------------------------------------|
| Attach your purchase receipt here. |
|------------------------------------|

Panasonic Canada Inc.
5770 Ambler Drive, Mississauga, Ontario L4W 2T3

© Panasonic System Networks Co., Ltd. 2013

Printed in China



PNQX6044YA

PNQX6044YA TT1013MU1014 (E)