

# Panasonic®

## Operating Instructions

**Expandable Digital Cordless Phone  
with 2 Handsets**

Model No. **KX-TG8202C**

**Expandable Digital Cordless  
Answering System**

Model No. **KX-TG8231C**

**with 2 Handsets**

Model No. **KX-TG8232C**

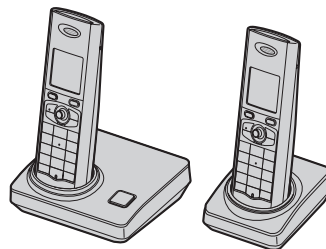

Model shown is KX-TG8202C.

DECT  
**6.0**

This unit is compatible with Call Display. To use this feature, you must subscribe to the appropriate service offered by your service provider/telephone company.

**Charge the handset batteries for 7 hours before initial use.**

Please read these Operating Instructions before using the unit and save them for future reference.

For assistance, please call **1-800-561-5505** or visit us at [www.panasonic.ca](http://www.panasonic.ca)

**Table of Contents**

**Introduction**

Product information . . . . . 3  
 Accessory information . . . . . 4  
 Important safety instructions . . . . . 6  
 For best performance . . . . . 8

**Preparation**

Controls . . . . . 10  
 Displays . . . . . 11  
 Connections . . . . . 12  
 Battery installation and replacement 13  
 Battery charge . . . . . 14  
 Screen saver mode . . . . . 15  
 Symbols used in these operating instructions . . . . . 15  
 Setting up the unit before use . . . . . 15

**Making/Answering Calls**

Making calls . . . . . 17  
 Answering calls . . . . . 18  
 Useful features during a call . . . . . 18

**Phonebook**

Handset phonebook . . . . . 20  
 Copying handset phonebook entries 23

**Call Display Service**

Using Call Display service . . . . . 24  
 Caller list . . . . . 25

**Programming**

Programmable settings . . . . . 27

**Answering System**

Answering system . . . . . 31  
 Turning the answering system on/off 31  
 Greeting message . . . . . 32  
 Listening to messages using the base unit . . . . . 33  
 Listening to messages using the handset . . . . . 33  
 Remote operation . . . . . 34  
 Answering system settings . . . . . 36

**Voice Mail Service**

Using Voice Mail service . . . . . 38

**Multi-unit Operation**

Operating additional handsets . . . . . 39  
 Intercom . . . . . 39  
 Transferring calls between handsets, conference calls . . . . . 39  
 Registering a handset to a base unit 40

**Useful Information**

Belt clip . . . . . 42  
 Headset (optional) . . . . . 42  
 Error messages . . . . . 43  
 Troubleshooting . . . . . 44  
 Industry Canada Notices and other information . . . . . 50  
 Specifications . . . . . 52  
 Warranty . . . . . 53

**Index**

Index . . . . . 54

**Introduction**

**Product information**

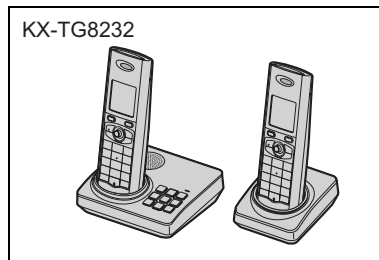
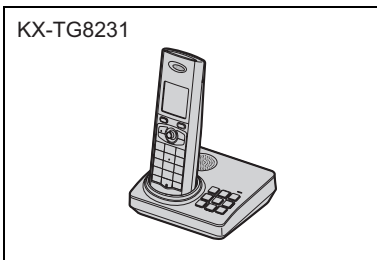
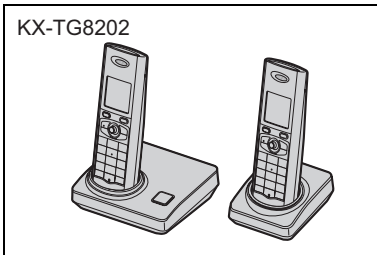

**Thank you for purchasing a Panasonic cordless telephone.**  
 These operating instructions can be used for the following models:



**Important:**

- The suffix (C) in the following model numbers will be omitted in these instructions:  
 KX-TG8202C/KX-TG8231C/KX-TG8232C

**Notable feature differences among the following models**

Model no.	Answering system	Intercom
		 ↔  *1
KX-TG8202	—	●
KX-TG8231	●	—*2
KX-TG8232	●	●

\*1 Intercom calls can be made between the handsets.

\*2 Intercom calls can be made between the handsets by purchasing and registering 1 or more optional handsets (KX-TGA820C, page 5).

## Introduction

## Accessory information

### Supplied accessories

No.	Accessory item	Quantity		
		KX-TG8202	KX-TG8231	KX-TG8232
①	AC adaptor for base unit	1	1	1
②	Telephone line cord	1	1	1
③	Rechargeable batteries AAA (R03) size	4	2	4
④	Handset cover <sup>*1</sup>	2	1	2
⑤	Belt clip	2	1	2
⑥	Charger	1	–	1
⑦	AC adaptor for charger	1	–	1

\*1 The handset cover comes attached to the handset.

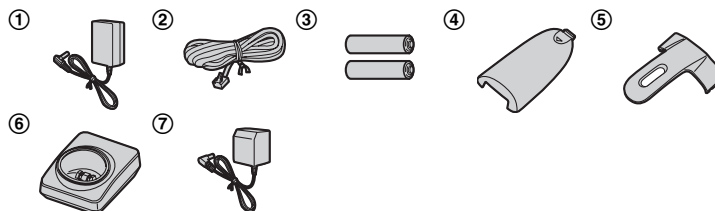

### Additional/replacement accessories

Accessory item	Order number
2 rechargeable nickel metal hydride (Ni-MH) batteries, AAA (R03) size	HHR-4MPA
Accessory handset with charger	KX-TGA820C
Headset	RP-TCA86, RP-TCA91, RP-TCA92, RP-TCA94, or RP-TCA95

## *Introduction*

### **Expanding your phone system**

You can expand the phone system by registering optional handsets to a single base unit.

- A maximum of 6 total handsets (supplied and optional) can be registered to a single base unit.

**Handset (optional): KX-TGA820C**



## Introduction

### Important safety instructions

When using the product, basic safety precautions should always be followed to reduce the risk of fire, electric shock, or personal injury.

1. Read all instructions carefully.
2. Follow all warnings and instructions marked on the product.
3. Unplug the product from power outlets before cleaning. Do not use liquid or aerosol cleaners. Use a dry soft cloth for cleaning.
4. Do not use the product near water, for example near a bathtub, wash bowl, kitchen sink, etc.
5. Place the product securely on a stable surface. Serious damage and/or injury may result if the product falls.
6. Do not cover slots and openings on the product. They are provided for ventilation and protection against overheating. Never place the product near radiators, or in a place where proper ventilation is not provided.
7. Use only the power source marked on the product. If you are not sure of the type of power supplied to your home, consult your dealer or local power company.
8. Do not place objects on the power cord. Install the product where no one can step or trip on the cord.
9. Do not overload power outlets and extension cords. This can result in the risk of fire or electric shock.
10. Never push any objects through slots in the product. This may result in the risk of fire or electric shock. Never spill any liquid on the product.
11. To reduce the risk of electric shock, do not disassemble the product. Take the product to an authorized service centre when service is required. Opening or removing covers may expose you to dangerous voltages or other risks. Incorrect reassembly can cause electric shock when the product is subsequently used.
12. Unplug the product from power outlets and take to an authorized service centre when the following conditions occur:
  - A. When the power cord is damaged or frayed.
  - B. If liquid has been spilled into the product.
  - C. If the product has been exposed to rain or water.
  - D. If the product does not work normally by following the operating instructions. Adjust only controls covered by the operating instructions. Improper adjustment may require extensive work by an authorized service centre.
  - E. If the product has been dropped or physically damaged.
  - F. If the product exhibits a distinct change in performance.
13. During thunderstorms, avoid using telephones except cordless types. There may be a remote risk of an electric shock from lightning.
14. Do not use the product to report a gas leak, when in the vicinity of the leak.

#### SAVE THESE INSTRUCTIONS

#### WARNING

- To prevent the risk of fire or electrical shock, do not expose the product to rain or any type of moisture.

## Introduction

- Unplug the product from power outlets if it emits smoke, an abnormal smell, or makes an unusual noise. These conditions can cause fire or electric shock. Confirm that smoke has stopped emitting and contact an authorized service centre.
- Do not spill liquids (detergents, cleansers, etc.) onto the telephone line cord plug, or allow it to become wet at all. This may cause a fire. If the telephone line cord plug becomes wet, immediately pull it from the telephone wall jack, and do not use.
- Do not place or use this product near automatically controlled devices such as automatic doors and fire alarms. Radio waves emitted from this product may cause such devices to malfunction resulting in an accident.
- Completely insert the AC adaptor/power plug into the power outlet. Failure to do so may cause electric shock and/or excessive heat resulting in a fire.
- Regularly remove any dust, etc. from the AC adaptor/power plug by pulling it from the power outlet, then wiping with a dry cloth. Accumulated dust may cause an insulation defect from moisture, etc. resulting in a fire.

### CAUTION

#### Installation

- Never install telephone wiring during a lightning storm.
- Never install telephone line jacks in wet locations unless the jack is specifically designed for wet locations.
- Never touch uninsulated telephone wires or terminals unless the telephone line has been disconnected at the network interface.

- Use caution when installing or modifying telephone lines.
- Do not touch the plug with wet hands.
- The AC adaptor is used as the main disconnect device. Ensure that the AC outlet is installed near the product and is easily accessible.

#### Battery

To reduce the risk of fire or injury to persons, read and follow these instructions.

- We recommend using the battery(ies) noted on page 4. **Use only rechargeable battery(ies).**
- Do not mix old and new battery(ies).
- Do not dispose of the battery(ies) in a fire, as they may explode. Check with local waste management codes for special disposal instructions.
- Do not open or mutilate the battery(ies). Released electrolyte is corrosive and may cause burns or injury to the eyes or skin. The electrolyte may be toxic if swallowed.
- Exercise care when handling the battery(ies). Do not allow conductive materials such as rings, bracelets or keys to touch the battery(ies), otherwise a short circuit may cause the battery(ies) and/or the conductive material to overheat and cause burns.
- Charge the battery(ies) provided with or identified for use with this product only in accordance with the instructions and limitations specified in this manual.
- Only use a compatible base unit (or charger) to charge the battery(ies). Do not tamper with the base unit (or charger). Failure to follow these instructions may cause the battery(ies) to swell or explode.

## Introduction

### Medical

- Consult the manufacturer of any personal medical devices, such as pacemakers or hearing aids, to determine if they are adequately shielded from external RF (radio frequency) energy. (The product operates in the frequency range of 1.92 GHz to 1.93 GHz, and the power output is 125 mW (max.).) Do not use the product in health care facilities if any regulations posted in the area instruct you not to do so. Hospitals or health care facilities may be using equipment that could be sensitive to external RF energy.

### Notice for product disposal, transfer, or return

- This product can store your private/confidential information. To protect your privacy/confidentiality, we recommend that you erase the information such as phonebook or caller list entries from the memory before you dispose, transfer or return the product.

## For best performance

### Base unit location/avoiding noise

The base unit and other compatible Panasonic units use radio waves to communicate with each other.

- For maximum coverage and noise-free communications, place your base unit:
  - at a convenient, high, and central location with no obstructions between the handset and base unit in an indoor environment.
  - away from electronic appliances such as TVs, radios, personal

computers, wireless devices or other phones.

- avoid facing radio frequency transmitters, such as external antennas of mobile phone cell stations (avoid putting the base unit on a bay window or near a window).
- Coverage and voice quality depends on the local environmental conditions.
- If the reception for a base unit location is not satisfactory, move the base unit to another location for better reception.

### Environment

- Keep the product away from electrical noise generating devices, such as fluorescent lamps and motors.
- The product should be kept free from excessive smoke, dust, high temperature, and vibration.
- The product should not be exposed to direct sunlight.
- Do not place heavy objects on top of the product.
- When you leave the product unused for a long period of time, unplug the product from the power outlet.
- The product should be kept away from heat sources such as heaters, kitchen stoves, etc. It should not be placed in rooms where the temperature is less than 5 °C (41 °F) or greater than 40 °C (104 °F). Damp basements should also be avoided.
- The maximum calling distance may be shortened when the product is used in the following places: Near obstacles such as hills, tunnels, underground, near metal objects such as wire fences, etc.
- Operating the product near electrical appliances may cause interference. Move away from the electrical appliances.



## *Introduction*

### **Routine care**

- **To clean the product, use a dry soft cloth. The outer surface of the product can be scratched by wiping or rubbing with a hard cloth.**
- Do not use benzine, thinner, or any abrasive powder.

## Preparation

### Controls

#### Base unit (KX-TG8202)

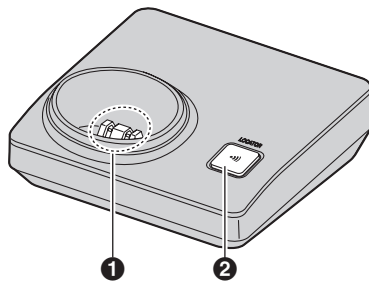

- 1 Charge contacts
- 2 [📶] (LOCATOR)

#### Base unit (KX-TG8231/KX-TG8232)

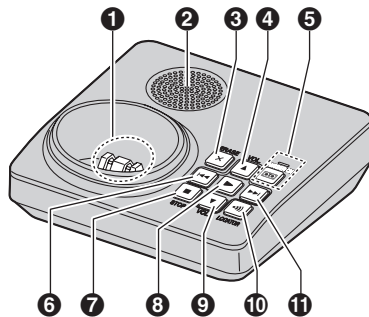

- 1 Charge contacts
- 2 Speaker
- 3 [X] (ERASE)
- 4 [▲] (VOL.: Volume up)
- 5 [📞] (ANSWER ON)  
ANSWER ON indicator
- 6 [↶] (Repeat)
- 7 [■] (STOP)
- 8 [▶] (Message)  
Message indicator

- 9 [▼] (VOL.: Volume down)
- 10 [📶] (LOCATOR)
- 11 [▶▶] (Skip)

#### Handset

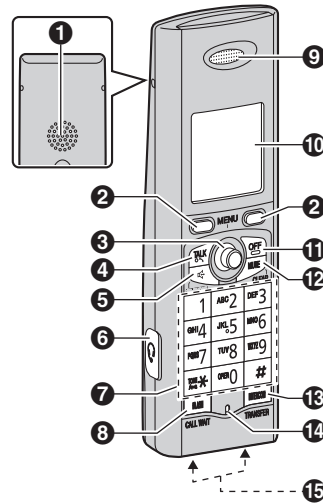

- 1 Speaker
- 2 Soft keys
- 3 Joystick
- 4 [📞] (TALK)
- 5 [📞] (SP-PHONE: Speakerphone)
- 6 Headset jack
- 7 Dial keypad  
([\*]: TONE)
- 8 [FLASH] [CALL WAIT]
- 9 Receiver
- 10 Display
- 11 [OFF]
- 12 [MUTE] [CLEAR]
- 13 [INTERCOM] [TRANSFER]
- 14 Microphone
- 15 Charge contacts

**Preparation**

**Using the joystick**

The handset joystick can be used to navigate through menus and to select items shown on the display, by pushing it up [▲], down [▼], left [◀], or right [▶].



**Adjusting the receiver or speaker volume**

Push the joystick up or down while talking.

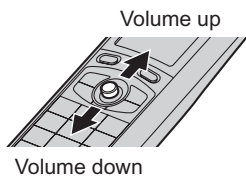

**Soft keys**

The handset features 2 soft keys and a joystick. By pressing a soft key, or by pressing the centre of the joystick, you can select the feature shown directly above it on the display.

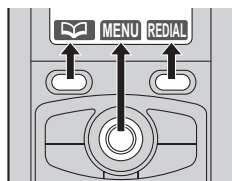

**Displays**

**Handset display items**

Item	Meaning
	Within range of a base unit <ul style="list-style-type: none"> <li>When flashing: Handset is searching for base unit (page 46).</li> </ul>
	Alarm is on. (page 30)
	Handset is on an outside call.
<b>SP</b>	Speaker is on.
	Ringer volume is off. (page 18, 27, 28)
<b>PRIV</b>	Call privacy mode is on. (page 19)
	Handset number
<b>In use</b>	<ul style="list-style-type: none"> <li>Line is being used by another handset for calling, registration, etc.</li> <li>Answering system is being used by another handset or the base unit.*1</li> </ul>
	Battery level

\*1 KX-TG8231/KX-TG8232

**Menu icons**

When in standby mode, pressing down on the centre of the joystick reveals the handset's main menu. From here you can access various features and settings.

Icon	Feature
	View Caller ID
	Display settings

## Preparation

Icon	Feature
	Set date & time
	Ringer settings* <sup>1</sup>
	Answering device* <sup>2</sup>
	Initial settings
	Customer support

\*1 KX-TG8202

\*2 KX-TG8231/KX-TG8232

## Connections

Connect the telephone line cord until it clicks into the base unit and telephone line jack (1). Connect the AC adaptor cord (2) by pressing the plug firmly (3).

### Base unit

- Use only the supplied Panasonic AC adaptor PQLV207.
- Use only the supplied telephone line cord.

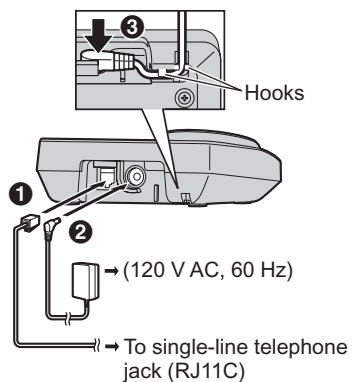

### Charger (KX-TG8202/KX-TG8232)

- Use only the supplied Panasonic AC adaptor PQLV209.

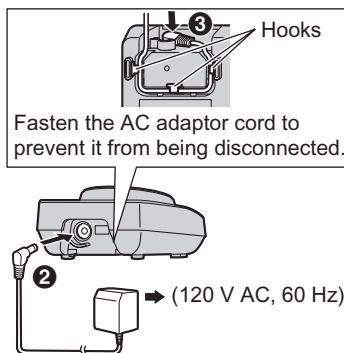

### Note:

- The AC adaptor must remain connected at all times. (It is normal for the adaptor to feel warm during use.)
- The AC adaptor should be connected to a vertically oriented or floor-mounted AC outlet. Do not connect the AC adaptor to a ceiling-mounted AC outlet, as the weight of the adaptor may cause it to become disconnected.
- The unit will not work during a power failure. We recommend connecting a corded telephone to the same telephone line or to the same telephone line jack using a T-adaptor.

## Preparation

### If you subscribe to a DSL service

Please attach a noise filter (contact your DSL provider) to the telephone line between the base unit and the telephone line jack in the event of the following:

- Noise is heard during conversations.
- Call Display features do not function properly.

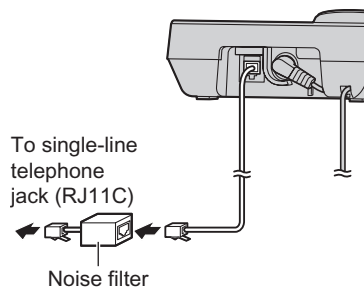

## Battery installation and replacement

### Important:

- Use only the supplied rechargeable batteries noted on page 4, 7.
- USE ONLY rechargeable Ni-MH batteries AAA (R03) size.
- Do NOT use Alkaline/Manganese/Ni-Cd batteries.
- Ensure correct polarities (+, -) when installing the batteries.
- Wipe the battery ends (+, -) with a dry cloth.
- When installing the batteries, avoid touching the battery ends (+, -) or the unit contacts.
- When replacing batteries, we recommend using the Panasonic rechargeable batteries noted on page 4, 7.

- 1 Press the notch on the handset cover firmly, and slide it in the direction of the arrow.

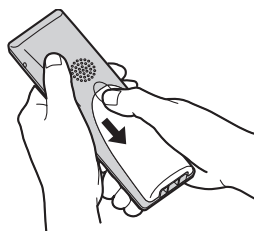

- 2 Insert the batteries negative (-) end first. Close the handset cover.

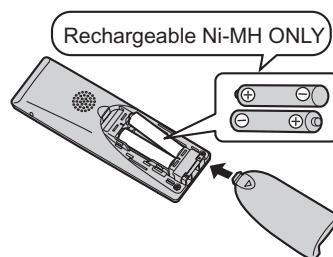

### Note:

- When replacing batteries, remove the old batteries.

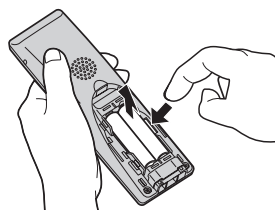

## Preparation

### Attention:



A nickel metal hydride battery that is recyclable powers the product you have purchased.

Please call 1-800-8-BATTERY (1-800-822-8837) for information on how to recycle this battery.

## Battery charge

Place the handset on the base unit or charger for 7 hours before initial use.

- While charging, "Charging" is displayed. When the batteries are fully charged, "Charge completed" is displayed.

Base unit\*1:

Charger\*2:

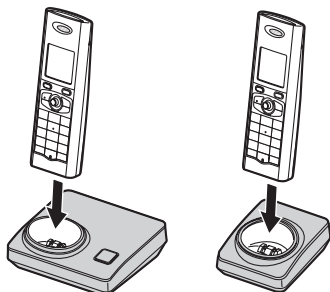

\*1 The pictured model is KX-TG8202.

\*2 KX-TG8202/KX-TG8232

### Note:

- It is normal for the handset to feel warm during charging.
- If you want to use the handset immediately, charge the batteries for at least 15 minutes.

- Clean the charge contacts of the handset, base unit, and charger with a soft, dry cloth once a month. Clean more often if the unit is subject to the exposure of grease, dust, or high humidity.
- When the batteries are empty, the entire display may go blank and "Charging" may not be displayed for about 10 minutes even if you place the handset on the base unit or charger.

### Battery level

Battery icon	Battery level
	High
	Medium
	Low <ul style="list-style-type: none"> <li>• When flashing: Needs to be charged.</li> </ul>

### Note:

- When the batteries need to be charged, the handset beeps intermittently during use.

### Panasonic Ni-MH battery performance (supplied batteries)

Operation	Operating time
In continuous use	12 hours max.
In continuous standby mode	150 hours max.

### Note:

- Battery operating time may be shortened over time depending on usage conditions and surrounding temperature.
- Battery power is consumed whenever the handset is off the base unit or charger, even when the handset is not in use.

## Preparation

- After the handset is fully charged, displaying "charge completed", it may be left on the base unit or charger without any ill effect on the batteries.
- The battery level may not be displayed correctly or the entire display may go blank after you replace the batteries. In this case, place the handset on the base unit or charger and let it charge for 7 hours.

### Screen saver mode

The backlight will turn off completely after 1 minute of inactivity if the handset is not on the base unit or charger. Press **[OFF]** to turn the display on again.

### Symbols used in these operating instructions

Symbol	Meaning
[ ]	The words in the brackets indicate button names/ soft key names on the handset and base unit. <b>Example:</b> Unit keys: <b>[RECALL]</b> , <b>[OFF]</b> Soft keys: <b>[CALL]</b> , <b>[REDIAL]</b>
→	Proceed to the next operation.
" "	The words in quotations indicate the menu on the display. <b>Example:</b> "Alarm"

Symbol	Meaning
<b>[▼]/[▲]</b> : " "	Push the handset joystick down or up to select the words in quotations. <b>Example:</b> <b>[▼]/[▲]</b> : "OFF"

### Setting up the unit before use

#### Display language

You can select either "English" or "Français" as the display language. The default setting is "English".

- 1 **[MENU]** (centre of joystick)
- 2 Select **[B]** by pushing the joystick in any direction. → **[SELECT]**
- 3 Push the joystick up or down to select "Change language". → **[SELECT]**
- 4 Push the joystick up or down to select the desired language.
- 5 Press down the centre of the joystick to save.
- 6 **[OFF]**

#### Note:

- How to change from French back to English:
  - ① **[MENU]** (centre of joystick) → **[B]** → **[SÉLEC.]**
  - ② **[▼]/[▲]**: "Changer langue" → **[SÉLEC.]**
  - ③ **[▼]/[▲]**: "English" → **[SAVE]** → **[OFF]**

## Preparation

### Voice guidance language

**Available for:**  
KX-TG8231/KX-TG8232

You can select either “**English**” or “**Français**” as the voice guidance language of the answering system (page 31). The default setting is “**English**”.

- 1 **[MENU]** (centre of joystick)
- 2 Select  by pushing the joystick in any direction. → **[SELECT]**
- 3 Push the joystick up or down to select “**settings**”. → **[SELECT]**
- 4 Push the joystick up or down to select “**Voice prompt**”. → **[SELECT]**
- 5 Push the joystick up or down to select the desired language. → **[SAVE]** → **[OFF]**

### Dialing mode

If you cannot make calls, change this setting according to your telephone line service. The default setting is “**Tone**”.

“**Tone**”: For tone dial service.  
“**Pulse**”: For rotary/pulse dial service.

- 1 **[MENU]** (centre of joystick)
- 2 Select  by pushing the joystick in any direction. → **[SELECT]**
- 3 Push the joystick up or down to select “**set tel line**”. → **[SELECT]**
- 4 Push the joystick up or down to select “**set dial mode**”. → **[SELECT]**
- 5 Push the joystick up or down to select the desired setting. → **[SAVE]** → **[OFF]**

### Date and time

Set the correct date and time so that:

- You can use the alarm function (page 30).
- The unit will announce the day and time a message was recorded when you play back on the answering system (page 33).

- 1 **[MENU]** (centre of joystick)
- 2 Select  by pushing the joystick in any direction. → **[SELECT]**
- 3 Push the joystick up or down to select “**Date and time**”. → **[SELECT]**
- 4 Enter the current month, date, and year.  
**Example:** August 15, 2007  
**[0][8] [1][5] [0][7]**
- 5 Enter the current hour and minute (12-hour clock format).  
**Example:** 9:30  
**[0][9] [3][0]**
- 6 Press **[\*]** to select “**AM**” or “**PM**”.
- 7 **[SAVE]** → **[OFF]**

#### Note:

- When English is selected as the display language, 12-hour clock format is used. When French is selected, 24-hour clock format is used.
- If you make a mistake when entering the date and time, push the joystick right, left, up, or down to move the cursor, then make the correction.
- The date and time may be incorrect after a power failure. In this case, set the date and time again.



## Making/Answering Calls

### Making calls

- 1 Dial the phone number.
  - To correct a digit, press **[CLEAR]**.
- 2 Press **[↶]**.
- 3 When you finish talking, press **[OFF]** or place the handset on the base unit or charger.

### Using the speakerphone

- 1 Dial the phone number, and press **[☎]**.
  - Speak alternately with the other party.
- 2 When you finish talking, press **[OFF]**.

#### Note:

- For best performance, use the speakerphone in a quiet environment.
- To switch back to the receiver, press **[↶]**.

### Adjusting the receiver/speaker volume

Push the joystick up or down repeatedly while talking.

### Making a call using the redial list

The last 5 phone numbers dialed are stored in the redial list (each 48 digits max.).

- 1 **[REDIAL]** (right soft key)
- 2 **[▼]/[▲]**: Select the desired phone number.
- 3 **[↶]**

### Erasing a number in the redial list

- 1 **[REDIAL]** (right soft key)

- 2 **[▼]/[▲]**: Select the desired phone number.

- 3 **[ERASE]**

- 4 **[▼]/[▲]**: "Yes" → **[SELECT]** → **[OFF]**

#### Note:

- Step 3 variation: **[MENU]** → **[▼]/[▲]**: "Erase" → **[SELECT]**

### Erasing all numbers in the redial list

- 1 **[REDIAL]** (right soft key)
- 2 **[MENU]** → **[▼]/[▲]**: "Erase all" → **[SELECT]**
- 3 **[▼]/[▲]**: "Yes" → **[SELECT]**

### PAUSE button (for PBX/long distance service users)

A pause is sometimes required when making calls using a PBX or long distance service. When storing a calling card access number and/or PIN in the phonebook, a pause is also needed (page 22).

For example, if you need to dial the line access number "9" when making outside calls with a PBX:

- 1 **[9]** → **[PAUSE]** → Dial the phone number.
- 2 **[↶]**

#### Note:

- A 3.5 second pause is inserted each time **[PAUSE]** is pressed. Press repeatedly to insert longer pauses.

## Making/Answering Calls

### Answering calls

- 1 Press [**hook**] or [**hook**] when the unit rings.
  - You can also answer the call by pressing any dial key from [**0**] to [**9**], [**\***], or [**#**]. (**Any key talk feature**)
- 2 When you finish talking, press [**OFF**] or place the handset on the base unit or charger.

**Note:**

- You can change the ringer tone (page 27, 28). You can also adjust the handset ringer volume (page 27, 28).

#### Auto talk

You can answer calls simply by lifting the handset off the base unit or charger. You do not need to press [**hook**]. To turn this feature on, see page 29.

#### Temporary ringer off

While the handset is ringing for a call, you can turn the ringer off temporarily by pressing [**hook**] or [**OFF**].

### Useful features during a call

#### MUTE button

While mute is turned on, you can hear the other party, but the other party cannot hear you.

- To mute your voice, press [**MUTE**].
- To return to the conversation, press [**MUTE**] again or [**hook**].

#### FLASH button

Pressing [**FLASH**] allows you to use special features of your host PBX such

as transferring an extension call, or accessing optional telephone services.

**Note:**

- To change the flash time, see page 29.

### For Call Waiting service users

To use Call Waiting, you must subscribe to the Call Waiting service of your service provider/telephone company. This feature allows you to receive calls while you are already talking on the phone. If you receive a call while on the phone, you will hear a Call Waiting tone. Please contact your service provider/telephone company for details and availability of this service in your area. Press [**CALL WAIT**] to answer the 2nd call.

- To switch between calls, press [**CALL WAIT**].

### Temporary tone dialing (for rotary/pulse service users)

You can temporarily switch the dialing mode to tone when you need to access touch-tone services (for example, answering services, telephone banking services, etc.). Press [**\***] (TONE) before entering access numbers which require tone dialing.

## Making/Answering Calls

### Call share

This feature allows the handset to join an existing outside call.

To join the conversation, press **[↶]** when the other handset is on an outside call.

**Note:**

- A maximum of 3 parties (including 1 outside party) can join a conversation using 2 extensions.

### Call privacy

Call privacy allows you to prevent other users from joining your conversations with outside callers. To allow other users to join your conversations, leave this feature off. The default setting is "Off".

- 1 Press **[MENU]** during an outside call.
- 2 **[▼]/[▲]**: "On" or "Off" → **[SELECT]**
  - When this feature is turned on, **PRIV** is displayed.

**Note:**





- This feature will turn off after you hang up the call.

## Phonebook



### Handset phonebook

The handset phonebook allows you to make calls without having to dial manually. You can add 50 names and phone numbers, assign each handset phonebook entry to the desired group.

#### Adding entries

- 1 **[** (left soft key)
- 2 **[ADD]**
- 3 Enter the party's name (16 characters max.). → **[OK]**
- 4 Enter the party's phone number (24 digits max.). → **[OK]**
- 5 **[]/**[**]: Select the desired group. → **[SELECT]****
- 6 **[]/**[**]: "save" → **[SELECT]**
  - To add other entries, repeat from step 3.**
- 7 **[OFF]**

#### Note:

- Step 2 variation:  
**[MENU]** → **[]/**[**]: "New entry"  
 → **[SELECT]****

#### Character table for entering names

While entering characters, you can switch between uppercase and lowercase by pressing **[\*]**.

Key	Character
<b>[1]</b>	Space # & ' ( ) * , - . / 1
<b>[2]</b>	A B C 2
	a b c 2
<b>[3]</b>	D E F 3
	d e f 3

Key	Character
<b>[4]</b>	G H I 4
	g h i 4
<b>[5]</b>	J K L 5
	j k l 5
<b>[6]</b>	M N O 6
	m n o 6
<b>[7]</b>	P Q R S 7
	p q r s 7
<b>[8]</b>	T U V 8
	t u v 8
<b>[9]</b>	W X Y Z 9
	w x y z 9
<b>[0]</b>	Space 0

- To enter another character that is located on the same dial key, first push the joystick right to move the cursor to the next space.

#### Correcting a mistake

Push the joystick left or right to move the cursor to the character or number you want to erase, then press **[CLEAR]**. Enter the appropriate character or number.

- Press and hold **[CLEAR]** to erase all characters or numbers.

#### Group settings

Group setting can help you find entries in the handset phonebook quickly and easily. When adding an entry to the handset phonebook you can assign it to the desired group. You can change the names of groups assigned for handset phonebook entries ("Friends", "Family", etc.) and then search for handset phonebook entries by group. Additional

## Phonebook

group setting features are available for Call Display subscribers (page 24).

### Changing group names

- 1 [☐] (left soft key) → [MENU]
- 2 [▼]/[▲]: "Group" → [SELECT]
- 3 [▼]/[▲]: Select the desired group. → [SELECT]
- 4 [▼]/[▲]: "Group name" → [SELECT]
- 5 Edit name (10 characters max.) → [SAVE] → [OFF]

### Finding and calling a handset phonebook entry

#### Scrolling through all entries

- 1 [☐] (left soft key)
- 2 [▼]/[▲]: Select the desired entry.
- 3 [↶]

#### Searching by first character (index search)

- 1 [☐] (left soft key)
- 2 Press the dial key ([0] – [9]) which contains the character you are searching for (see the character table, page 20).
  - Press the same dial key repeatedly to display the first entry corresponding to each letter located on that dial key.
  - If there is no entry corresponding to the character you selected, the next entry is displayed.
- 3 [▼]/[▲]: Scroll through the phonebook if necessary.
- 4 [↶]

#### Searching by group

- 1 [☐] (left soft key) → [GROUP]

- 2 [▼]/[▲]: Select the desired group. → [SELECT]
  - If you select "All groups", the unit will end searching group.
- 3 [▼]/[▲]: Scroll through the phonebook if necessary.
- 4 [↶]

### Editing entries

- 1 Find the desired entry (page 21).
- 2 [EDIT]
- 3 Edit the name if necessary (see the character table, page 20). → [OK]
- 4 Edit the phone number if necessary (24 digits max.). → [OK]
- 5 [▼]/[▲]: Select the desired group. → [SELECT]
- 6 [▼]/[▲]: "Save" → [SELECT] → [OFF]

#### Note:

- Step 2 variation:  
[MENU] → [▼]/[▲]: "Edit" → [SELECT]

### Erasing entries

#### Erasing an entry

- 1 Find the desired entry (page 21).
- 2 [MENU]
- 3 [▼]/[▲]: "Erase" → [SELECT]
- 4 [▼]/[▲]: "Yes" → [SELECT] → [OFF]

#### Erasing all entries

- 1 [☐] (left soft key)
- 2 [MENU]
- 3 [▼]/[▲]: "Erase all" → [SELECT]
- 4 [▼]/[▲]: "Yes" → [SELECT]

## Phonebook

5 [▼]/[▲]: "Yes" → [SELECT] → [OFF]

### One touch dial

#### Assigning an entry in the handset phonebook to a one touch dial key

Dial keys [1] to [9] can each be used as a one touch dial key, allowing you to dial a number from the handset phonebook by simply pressing a dial key.

- 1 Find the desired entry (page 21). → [MENU]
- 2 [▼]/[▲]: "1-touch dial" → [SELECT]
- 3 [▼]/[▲]: Select the desired dial key number. → [SELECT]
  - When the dial key is already used as a one touch dial key, "\*" is displayed next to the dial key number. If you select this dial key, you can overwrite the previous assignment.
- 4 [▼]/[▲]: "save" → [SELECT] → [OFF]

#### Making a call using a one touch dial key

- 1 Press and hold the desired one touch dial key ([1] to [9]).
  - You can view other one touch dial assignments by pushing the joystick up or down.
- 2 [↶]

#### Cancelling a one touch dial assignment

- 1 Press and hold the desired one touch dial key ([1] to [9]).
- 2 [ERASE]

3 [▼]/[▲]: "Yes" → [SELECT] → [OFF]

#### Note:

- Step 2 variation:  
[MENU] → [▼]/[▲]: "Erase" → [SELECT]

### Chain dial

This feature allows you to dial phone numbers in the handset phonebook while you are on a call. This feature can be used, for example, to dial a calling card access number or bank account PIN that you have stored in the handset phonebook, without having to dial manually.

- 1 During an outside call, press [☎].
- 2 [▼]/[▲]: Select the desired entry.
- 3 Press [CALL] to dial the number.

#### Note:

- When storing a calling card access number and your PIN in the phonebook as one phonebook entry, press [PAUSE] to add pauses after the number and PIN as necessary (page 17).
- If you have rotary/pulse service, you need to press [\*] before pressing [☎] in step 1 to change the dialing mode temporarily to tone.

## Copying handset phonebook entries

You can copy handset phonebook entries to the handset phonebook of another compatible Panasonic handset.

### Note:

- Group settings for phonebook entries are not copied.

### Copying an entry

- 1 Find the desired entry (page 21). → **[MENU]**
- 2 **[▼]/[▲]**: "Copy" → **[SELECT]**
- 3 Select the handset to copy to by pressing the desired handset number (**[1]** – **[6]**).
  - When an entry has been copied, "Completed" is displayed.
  - To continue copying another entry:  
**[▼]/[▲]**: "Yes" → **[SELECT]** → Find the desired entry. → **[OK]**
- 4 **[OFF]**

### Copying all entries

- 1 **[☰]** (left soft key) → **[MENU]**
- 2 **[▼]/[▲]**: "Copy all" → **[SELECT]**
- 3 Select the handset to copy to by pressing the desired handset number (**[1]** – **[6]**).
  - When all entries have been copied, "Completed" is displayed.
- 4 **[OFF]**

## Call Display Service

### Using Call Display service

#### Important:

- This unit is Call Display compatible. To use Call Display features, you must subscribe to Call Display service. Consult your service provider/telephone company for details.

#### Call Display features

When an outside call is being received, the calling party's name and phone number are displayed.

Caller information for the last 50 callers is logged in the caller list by the most recent call to the oldest.

- Generally caller information is displayed from the 2nd ring.
- If the unit cannot receive caller information, the following is displayed:
  - “**Unavailable Name & No.**”: The caller dialed from an area which does not provide Call Display service.
  - “**Private caller**”: The caller requested not to send caller information.
  - “**Long distance**”: The caller called you long distance.
- If the unit is connected to a PBX system, caller information may not be received properly. Consult your PBX supplier.

#### Missed calls

If a call is not answered, the unit treats the call as a missed call. The display shows “**missed call**”. This lets you know if you should view the caller list to see who called while you were out.

#### Custom name display

When the Call Display number is received and it matches a phone number stored in the phonebook, the stored name from the phonebook is displayed and logged in the caller list.

#### Visual Call Waiting service

If you subscribe to both Call Display and Visual Call Waiting services, the 2nd caller's information is displayed after you hear a Call Waiting tone.

Press **[CALL WAIT]** to answer the 2nd call.

- To switch between calls, press **[CALL WAIT]**.

#### Note:

- Please contact your service provider/telephone company for details and availability of this service in your area.

### Group settings for handset phonebook

Group settings can help you identify who is calling by using different ringer tones and display colours for different groups of callers. When adding an entry to the handset phonebook you can assign it to desired group (page 20). When a call is received from a caller assigned to a group, the group's display colours and ringer tone you selected are used.

#### Changing group ringer tones

If you select “**No ringer ID**”, the unit will use the external ringer tone you set on page 28 when calls from this group are received. The default is “**No ringer ID**”.

- 1 **[M]** (left soft key) → **[MENU]**
- 2 **[v]/[^]**: “**Group**” → **[SELECT]**



## Call Display Service

- 3 **[▼]/[▲]**: Select a group. → **[SELECT]**
- 4 **[▼]/[▲]**: Select the current setting of the group ringer tone. → **[SELECT]**
- 5 **[▼]/[▲]**: Select the desired ringer tone. → **[SAVE]** → **[OFF]**

### Changing group display colours

If you select "No colour ID", the unit will use the display colour you set on page 28 when calls from this group are received. The default is "No colour ID".

- 1 **[M]** (left soft key) → **[MENU]**
- 2 **[▼]/[▲]**: "Group" → **[SELECT]**
- 3 **[▼]/[▲]**: Select a group. → **[SELECT]**
- 4 **[▼]/[▲]**: Select the current setting of the group colour. → **[SELECT]**
- 5 **[▼]/[▲]**: Select the desired colour. → **[SAVE]** → **[OFF]**

## Caller list

### Viewing the caller list and calling back

- 1 **[MENU]** (centre of joystick) → **[SELECT]**
- 2 Push the joystick down to search from the most recent call, or push the joystick up to search from the oldest call.
- 3 To call back, press **[↩]**. To exit, press **[OFF]**.

#### Note:

- If the item has already been viewed or answered, "✓" is displayed, even if it was viewed or answered using another handset.

### Editing a caller's phone number before calling back

You can edit a phone number in the caller list by adding the long distance code "1" or removing its area code.

- 1 **[MENU]** (centre of joystick) → **[SELECT]**
- 2 **[▼]/[▲]**: Select the desired item. → **[EDIT]**
- 3 Press **[EDIT]** repeatedly until the phone number is shown in the desired format.
  - ① 1 – Area code – Local phone number  
**Example:**
  - ② Local phone number  
**Example:**
  - ③ Area code – Local phone number  
**Example:**
- 4 **[↩]**

#### Note:

- The number edited in step 3 will not be saved in the caller list.

### Erasing selected caller information

- 1 **[MENU]** (centre of joystick) → **[SELECT]**
- 2 **[▼]/[▲]**: Select the desired item.
- 3 **[ERASE]**
- 4 **[▼]/[▲]**: "Yes" → **[SELECT]** → **[OFF]**

## Call Display Service

### Erasing all caller information

- 1 **[MENU]** (centre of joystick) → →  
→ **[SELECT]**
- 2 **[ERASE]**
- 3 **[▼]/[▲]**: "yes" → **[SELECT]**

### Storing caller information into the phonebook

- 1 **[MENU]** (centre of joystick) → →  
→ **[SELECT]**
- 2 **[▼]/[▲]**: Select the desired item.
  - To edit the number, press **[EDIT]** repeatedly until the phone number is shown in the desired format.
- 3 **[SAVE]**
- 4 Edit the name if necessary (see the character table, page 20). → **[OK]**
- 5 Edit the phone number if necessary.  
→ **[OK]**
- 6 **[▼]/[▲]**: Select the desired group.  
→ **[SELECT]**
- 7 **[▼]/[▲]**: "save" → **[SELECT]** →  
**[OFF]**

## Programming

### Programmable settings

You can customize the unit by programming the following features using the handset.

#### Programming by scrolling through the display menus



- 1 **[MENU]** (centre of joystick)
- 2 Select "Menu icon" by pushing the joystick in any direction. → **[SELECT]**
- 3 Push the joystick up or down to select the desired item in the sub-menu. → **[SELECT]**
  - In some cases, you may need to select from a second sub-menu. → **[SELECT]**
- 4 Push the joystick up or down to select the desired setting then press **[SAVE]**.
  - This step may vary depending on the feature being programmed.
  - To exit the operation, press **[OFF]**.

#### Note:



- In the following table, < > indicates the default setting.
- The current item or setting is highlighted on the display.

Main menu	Sub-menu 1	Sub-menu 2	Page
View Caller ID ➔	–	–	25
Display settings 📄	Wallpaper <Wallpaper1 >	–	–
	Display colour <Colour1>	–	–
	Change language <English>	–	15
	Contrast <Contrast 3>	–	–
Set date & time 🕒	Date and time <sup>*1</sup>	–	16
	Alarm <Off>	–	30
	Time adjustment <sup>*1, *2</sup> <Caller ID[auto]>	–	–
Ringer settings 🎵 (KX-TG8202)	Ringer volume <Level 6> <sup>*3</sup>	–	–
	Ringer tone <sup>*4, *5, *6</sup> <Tone 1>	–	–

## Programming

Main menu	Sub-menu 1	Sub-menu 2	Page	
<b>Answering device</b>  (KX-TG8231/ KX-TG8232)	Play new msg.	-	33	
	Play all msg.	-	33	
	Record greeting <sup>*1</sup>	-	32	
	Answer on <sup>*1</sup> Answer off <sup>*1</sup> <Answer on>	-	31	
	Play greeting	-	32	
	Erase message	Erase all <sup>*1</sup>		33
		Erase greeting <sup>*1</sup>		32
	Settings	Remote code <sup>*1</sup> <111>		36
		Ring count <sup>*1</sup> <4 rings>		36
		Recording time <sup>*1</sup> <3 min>		36
		Call screening <sup>*1</sup> <On>		37
		Voice prompt <sup>*1</sup> <English>		16
	<b>Initial settings</b> 	Ringer settings	Ringer volume <Level 6> <sup>*3</sup>	-
Ringer tone <sup>*4, *5, *6</sup> <Tone 1>			-	
Display settings		Wallpaper <Wallpaper1 >	-	
		Display colour <Colour1>	-	
		Change language <English>	15	
		Contrast <Contrast 3>	-	
Registration		HS registration (Handset registration)		40
		Deregistration		40

**Programming**

Main menu	Sub-menu 1	Sub-menu 2	Page
Initial settings 	Set tel line	Set dial mode <sup>*1</sup> <Tone>	16
		Set flash time <700 ms> <sup>*1, *7</sup>	18
	Other settings	Key tone <sup>*8</sup> <On>	–
		Auto talk <sup>*9</sup> <Off>	18
Customer support 	–	–	30

\*1 If you program these settings using one of the handsets, you do not need to program the same item using another handset.

\*2 This feature allows the unit to automatically adjust the date and time setting when caller information is received. To use this feature, set the date and time first.

\*3 When the ringer volume is turned off,  $\mathcal{R}$  is displayed and the handset does not ring for outside calls.

However even when the ringer volume is turned off, the handset rings:

- at the minimum level for alarm and intercom calls
- at the maximum level for paging

\*4 If you subscribe to a distinctive ring service, select a tone (tone 1 to 5). If you select a melody, you cannot distinguish lines by their ringers.

\*5 The preset melodies in this product are used with permission of © 2006 Copyrights Vision Inc.

\*6 If you select one of the melody ringer tones, the ringer tone will continue to sound for several seconds if the caller hangs up before you answer. You may hear a dial tone or no one on the line when you answer a call.

\*7 The flash time depends on your telephone exchange or host PBX. Consult your PBX supplier if necessary.

\*8 Turn this feature off if you prefer not to hear key tones while you are dialing or pressing any keys, including confirmation tones and error tones.

\*9 If you subscribe to Call Display service and want to view the caller's information after lifting up the handset to answer a call, turn off this feature.

## Programming

### Alarm

An alarm will sound at the set time for 3 minutes in two different alarm modes: Once or Daily. Set the date and time beforehand (page 16).

- 1 **[MENU]** (centre of joystick) →  → **[SELECT]**
- 2 **[v]/[▲]**: "Alarm" → **[SELECT]**
- 3 **[v]/[▲]**: Select the desired alarm mode. → **[SELECT]**

<b>off</b>	Turns alarm off. Press <b>[SELECT]</b> again, then press <b>[OFF]</b> to exit.
<b>Once</b>	The alarm sounds once at the set time. Enter the desired month and date.
<b>Daily</b>	An alarm sounds daily at the set time.

- 4 Set the desired time. → **[OK]**
- 5 **[v]/[▲]**: Select the desired ringer tone. → **[SELECT]**
  - We recommend selecting a different ringer tone from outside call.
- 6 **[v]/[▲]**: "save" → **[SELECT]** → **[OFF]**
  - When the alarm is set,  is displayed.

#### Note:

- To stop the alarm, press any dial key or place the handset on the base unit or charger.
- When the handset is in use, the alarm will not sound until the handset is in standby mode.
- If you select "once", the setting will change to "off" after the alarm sounds.

### Customer support

The handset can display the Internet address where you can download the operating instructions or get further information for this product by using your computer.

- 1 **[MENU]** (centre of joystick) →  → **[SELECT]**
- 2 **[OFF]**

## Answering System

### Answering system

**Available for:**  
KX-TG8231/KX-TG8232

The answering system can answer and record calls for you when you are unavailable to answer the phone.

**Important:**

- Only 1 person can access the answering system (listen to messages, record a greeting message, etc.) at a time.
- When callers leave messages, the unit records the day and time of each message. Make sure the date and time have been correctly set (page 16).

### Memory capacity

The total recording capacity (including your greeting message and caller messages) is about 16 minutes. A maximum of 64 messages can be recorded.

**Note:**

- If message memory becomes full:
  - “**Messages full**” is shown on the handset display
  - the message indicator on the base unit flashes rapidly
- When the message memory becomes full, the greeting message is different depending on your situation:
  - If you use the prerecorded greeting message, the unit automatically switches to another prerecorded greeting message asking callers to call again later.
  - If you recorded your own greeting message, the same message is still announced to callers even though their messages are not recorded.

### Turning the answering system on/off

#### Using the base unit

Press **[ON]** (ANSWER ON) to turn on/off the answering system.

- When the answering system is turned on, the ANSWER ON indicator lights up.

#### Using the handset

- 1 **[MENU]** (centre of joystick) → **[ON]** → **[SELECT]**
- 2 **[V]/[A]**: “Answer on” or “Answer off” → **[SELECT]** → **[OFF]**

### Call screening

While a caller is leaving a message, you can listen to the call through the handset’s speaker.

You can answer the call by pressing **[hook]** on the handset.

**Note:**

- To temporarily mute call screening on the handset, press **[SILENCE]**. To screen again in the call, push the joystick up accordingly.
- To turn this feature off, see page 37.

## Answering System

### Greeting message

When the unit answers a call, callers are greeted by a greeting message. You can record your own greeting message or use a pre-recorded greeting message.

### Recording your greeting message

You can record your own greeting message (2 minutes and 30 seconds max.).

- 1 **[MENU]** (centre of joystick) → **[OK]** → **[SELECT]**
- 2 **[▼]/[▲]**: "Record greeting" → **[SELECT]**
- 3 Hold the handset about 20 cm (8 inches) away and speak clearly into the microphone.
- 4 To stop recording, press **[STOP]**.
- 5 **[OFF]**

### Using a pre-recorded greeting message

If you erase or do not record your own greeting message, the unit plays a pre-recorded greeting message for callers and asks them to leave messages.

### Playing back the greeting message

- 1 **[MENU]** (centre of joystick) → **[OK]** → **[SELECT]**
- 2 **[▼]/[▲]**: "Play greeting" → **[SELECT]** → **[OFF]**

#### Note:

- You can erase your own greeting message by pressing **[ERASE]** during playback.

### Erasing your greeting message

If you erase your own greeting message, the unit will play a pre-recorded greeting message for callers.

- 1 **[MENU]** (centre of joystick) → **[OK]** → **[SELECT]**
- 2 **[▼]/[▲]**: "Erase message" → **[SELECT]**
- 3 **[▼]/[▲]**: "Erase greeting" → **[SELECT]**
- 4 **[▼]/[▲]**: "Yes" → **[SELECT]** → **[OFF]**



## Answering System

### Listening to messages using the base unit

When new messages have been recorded, the message indicator on the base unit flashes.

Press **[▶]** (Message).

- If new messages have been recorded, the base unit plays back new messages.
- If there are no new messages, the base unit plays back all messages.

**Note:**

- When the message indicator on the base unit flashes rapidly, the message memory is full ("Memory capacity", page 31).

### Operating the answering system

Key	Operation
<b>[▲]</b> or <b>[▼]</b>	Adjust the speaker volume (during playback)
<b>[◀◀]</b>	Repeat message (during playback)*1
<b>[▶▶]</b>	Skip message (during playback)
<b>[■]</b> (STOP)	Stop playback
<b>[X]</b> (ERASE)	Erase currently playing message

\*1 If pressed within the first 5 seconds of a message, the previous message is played.

#### Erasing all messages

Press **[X]** (ERASE) 2 times while the unit is not being used.

### Listening to messages using the handset

When new messages have been recorded, "New message" is displayed.

- 1 **[MENU]** (centre of joystick) → **[☎]** → **[SELECT]**
- 2 **[▼]/[▲]**: "Play new msg." or "Play all msg." → **[SELECT]**
- 3 When finished, press **[OFF]**.

**Note:**

- To switch to the receiver, press **[↶]**.

#### Calling back (Call Display subscribers only)

If caller information was received for the call, you can call the caller back while listening to a message.

- 1 Press **[MENU]** during playback.
- 2 **[▼]/[▲]**: "Edit & Call" → **[SELECT]**
  - Press **[EDIT]** repeatedly until the phone number is shown in the desired format.

- 3 **[CALL]**

#### Erasing all messages

- 1 **[MENU]** (centre of joystick) → **[☎]** → **[SELECT]**
- 2 **[▼]/[▲]**: "Erase message" → **[SELECT]**
- 3 **[▼]/[▲]**: "Erase all" → **[SELECT]**
- 4 **[▼]/[▲]**: "Yes" → **[SELECT]** → **[OFF]**

## Answering System

### Operating the answering system

You can also operate the answering system by pressing dial keys on the handset.

To use the following commands:  
**[MENU]** (centre of joystick) →  → **[SELECT]**

Key	Operation
Pushing the joystick up or down	Adjust the receiver/speaker volume (during playback)
<b>[1]</b> or push the joystick left	Repeat message (during playback)* <sup>1</sup>
<b>[2]</b> or push the joystick right	Skip message (during playback)
<b>[3]</b>	Enter the "settings" menu
<b>[4]</b>	Play new messages
<b>[5]</b>	Play all messages
<b>[6]</b>	Play greeting message
<b>[7][6]</b>	Record greeting message
<b>[8]</b>	Turn answering system on
<b>[9]</b>	Stop (recording, playback)
<b>[0]</b>	Turn answering system off
<b>[*][4]</b> <sup>2</sup>	Erase currently playing message
<b>[*][5]</b>	Erase all messages
<b>[*][6]</b>	Erase greeting message

\*1 If pressed within the first 5 seconds of a message, the previous message is played.

\*2 You can also erase as follows:  
**[ERASE]** → **[▼]/[▲]**: "yes" → **[SELECT]**

### Remote operation

Using a touch-tone phone, you can call your phone number from outside and access the unit to listen to messages or change answering system settings. The unit's voice guidance will prompt you to press certain dial keys to perform different operations.

#### Important:

- In order to operate the answering system remotely, you must first set a remote access code (page 36). This code must be entered each time you operate the answering system remotely.

### Using the answering system remotely

- 1 Dial your phone number from a touch-tone phone.
- 2 After the greeting message starts, enter your remote access code (page 36).
  - The unit announces the number of new messages.
  - The voice guidance informs you of the available commands.
- 3 Control the unit using remote commands (page 35).
- 4 When finished, hang up.

### Voice guidance

During remote operation, the unit's voice guidance starts and prompts you

## Answering System

to press **[1]** to perform a specific operation, or press **[2]** to listen to more available operations. Operations are presented by voice guidance in the following order:

- Play back all messages
- Play back new messages
- Record a message
- Erase all messages
- Record a greeting message

### Note:

- If you do not press any dial keys within 10 seconds after a voice guidance prompt, the unit disconnects your call.

### Remote commands

You can press dial keys to access certain answering system functions without waiting for the voice guidance to prompt you.

Key	Operation
<b>[1]</b>	Repeat message (during playback) <sup>*1</sup>
<b>[2]</b>	Skip message (during playback)
<b>[4]</b>	Play new messages
<b>[5]</b>	Play all messages
<b>[6]</b>	Play greeting message
<b>[7]</b>	Record greeting message
<b>[9]</b>	Stop recording Stop playback <sup>*2</sup>
<b>[0]</b>	Turn answering system off
<b>[*][4]</b>	Erase currently playing message
<b>[*][5]</b>	Erase all messages

Key	Operation
<b>[*][6]</b>	Erase greeting message (during greeting message playback)
<b>[*][#]</b>	End remote operation (or hang up)

\*1 If pressed within the first 5 seconds of a message, the previous message is played.

\*2 To resume operation, enter a remote command within 3 seconds, or the voice guidance starts.

### Turning on the answering system remotely

If the answering system is off, you can turn it on remotely.

- 1 Dial your phone number from a touch-tone phone.
- 2 Let the phone ring 15 times.
  - A long beep will be heard.
- 3 Enter your remote access code within 10 seconds after the long beep.
  - The greeting message is played back.
  - You can hang up, or enter your remote access code again and begin remote operation (page 34).

### Skipping the greeting message to leave a message

You can leave a message just as any outside caller can. Call your phone number. When the answering system picks up, press **[\*]** to skip the greeting message and record your message after the beep.

## Answering System

### Answering system settings

#### Remote access code

A 3-digit remote access code must be entered when operating the answering system remotely. This code prevents unauthorized parties from listening to your messages remotely. The default setting is "111".

- 1 **[MENU]** (centre of joystick) →  → **[SELECT]**
- 2 **[▼]/[▲]**: "Settings" → **[SELECT]**
- 3 **[▼]/[▲]**: "Remote code" → **[SELECT]**
- 4 Enter the desired 3-digit remote access code. → **[SAVE]** → **[OFF]**

#### Ring count

You can change the number of times the phone rings before the unit answers calls. You can select 2 to 7 rings, or "Toll saver".

The default setting is "4 rings".  
 "Toll saver": The unit's answering system answers at the end of 2nd ring when new messages have been recorded, or at the end of 4th ring when there are no new messages. If you call your phone from outside to listen to new messages (page 34), you will know that there are no new messages when the phone rings for the 3rd time. You can then hang up without being charged for the call.

- 1 **[MENU]** (centre of joystick) →  → **[SELECT]**
- 2 **[▼]/[▲]**: "Settings" → **[SELECT]**

- 3 **[▼]/[▲]**: "Ring count" → **[SELECT]**
- 4 **[▼]/[▲]**: Select the desired setting.
- 5 **[SAVE]** → **[OFF]**

#### For Voice Mail service subscribers

If you subscribe to a flat-rate service package that includes Call Display, Call Waiting, Voice Mail, and unlimited local/regional/long distance calls, please note the following:

- To use the Voice Mail service provided by your service provider/telephone company rather than the unit's answering system, turn off the answering system (page 31).
- To use this unit's answering system rather than the Voice Mail service provided by your service provider/telephone company, please contact your service provider/telephone company to deactivate your Voice Mail service.

If your service provider/telephone company cannot do this:

- Set this unit's "Ring count" setting so that this unit's answering system answers calls before the Voice Mail service of your service provider/telephone company does. It is necessary to check the ring count required to activate the Voice Mail service provided by your service provider/telephone company before changing this setting.
- Change the ring count of the Voice Mail service so that the answering system can answer the call first. To do so, consult your service provider/telephone company.

#### Caller's recording time

You can change the maximum message recording time allotted to

## Answering System

each caller. The default setting is "3 min".

- 1 **[MENU]** (centre of joystick) → **[OK]**  
→ **[SELECT]**
- 2 **[▼]/[▲]**: "Settings" → **[SELECT]**
- 3 **[▼]/[▲]**: "Recording time" → **[SELECT]**
- 4 **[▼]/[▲]**: Select the desired setting.
- 5 **[SAVE]** → **[OFF]**

---

### Call screening

You can set the call screening feature "on" or "off". For details, see page 31. The default setting is "on".

- 1 **[MENU]** (centre of joystick) → **[OK]**  
→ **[SELECT]**
- 2 **[▼]/[▲]**: "Settings" → **[SELECT]**
- 3 **[▼]/[▲]**: "Call screening" → **[SELECT]**
- 4 **[▼]/[▲]**: Select the desired setting.
- 5 **[SAVE]** → **[OFF]**

## Voice Mail Service

### Using Voice Mail service

Voice Mail is an automatic answering service offered by your service provider/telephone company. After you subscribe to this service, the service provider/telephone company's Voice Mail system will answer calls for you when you are unavailable to answer the phone or when your line is busy. Messages are recorded by the service provider/telephone company, not your telephone.

**Important:**

- To use the Voice Mail service provided by your service provider/telephone company rather than the unit's answering system, turn off the answering system (page 31). For details, see page 36 (KX-TG8231/KX-TG8232).

**Voice Mail message indication**

When you have new messages, "New Voice Mail" is displayed on the handset.

- In order to listen to your Voice Mail messages, you must dial your service provider/telephone company's Voice Mail access number.

**Note:**

- If the handset still indicates there are new messages even after you have listened to new messages, turn it off by pressing and holding **[CLEAR]** until the handset beeps.
- The indication of "New Voice Mail" may not display properly depending on availability of your service provider/telephone company. Please

contact your service provider/telephone company for details.

## Multi-unit Operation

### Operating additional handsets

#### Additional handsets

Up to 6 handsets can be registered to the base unit.

#### Important:

- See page 5 for information on the available model.
- Additional handsets will give you the freedom to, for example, have an intercom call with another handset while a third handset is on an outside call.

### Intercom

Intercom calls can be made between handsets.

#### Note:

- If you receive an outside call while talking on the intercom, you hear 2 tones. To answer the call, press **[OFF]**, then press **[↶]**.
- When paging a unit for an intercom call, the paged unit beeps for 1 minute.

#### Making an intercom call

- 1 [INTERCOM]**
- Select the handset you want to page by pressing the desired handset number (**[1]** – **[6]**).
  - To stop paging, press **[OFF]**.
- When you finish talking, press **[OFF]**.

#### Answering an intercom call

- Press **[↶]** or **[↷]** to answer the page.
- When you finish talking, press **[OFF]**.

#### Handset locator

You can locate a misplaced handset by paging it.

- Base unit:**  
**[••)]** (LOCATOR)
  - The handset beeps for 1 minute.
- To stop paging:  
**Base unit:**  
Press **[••)]** (LOCATOR).  
**Handset:**  
Press **[OFF]**.

### Transferring calls between handsets, conference calls

Outside calls can be transferred between 2 handsets. 2 handsets can have a conference call with an outside party.

- During an outside call, press **[TRANSFER]** to put the call on hold.
- Select the handset you want to transfer to by pressing the desired handset number (**[1]** – **[6]**).
- Wait for the paged party to answer.
  - If the paged party does not answer, press **[↶]** to return to the outside call.
- To complete the transfer:**  
Press **[OFF]**.
  - The outside call is being routed to the handset.

## Multi-unit Operation

**To establish a conference call:**  
Press **[CONF]**.

- To leave the conference, press **[OFF]**. The other parties can continue the conversation.

### Answering transferred calls

Press **[↶]** to answer the page.

- After the paging party disconnects, you can talk to the outside caller.

### Transferring a call without speaking to the other handset user

- 1 During an outside call, press **[TRANSFER]**. → Press the desired handset number.
  - **[↶]** flashes to indicate the outside call is on hold.

### 2 [OFF]

- The outside call rings at the other handset.

### Note:

- If the other handset user does not answer the call within 1 minute, the call will ring at your handset again.

## Registering a handset to a base unit

The supplied handset and base unit are pre-registered. If for some reason the handset is not registered to the base unit (for example, **[Y]** flashes even when the handset is near the base unit), register the handset.

- 1 **[MENU]** (centre of joystick) → **[↷]**  
→ **[SELECT]**
- 2 **[▼]/[▲]**: "Registration" → **[SELECT]**
- 3 **[▼]/[▲]**: "HS registration" → **[SELECT]**
- 4 **Base unit:**

Proceed with the operation for your model.

### ■ KX-TG8202

Press and hold **[↷]** (LOCATOR) on the base unit for about 5 seconds. (No registration tone)

### ■ KX-TG8231/KX-TG8232

Press and hold **[↷]** (LOCATOR) on the base unit for about 5 seconds, until the registration tone sounds.

- If all registered handsets start ringing, press **[↷]** (LOCATOR) to stop, then repeat this step.
- After pressing **[↷]** (LOCATOR), the rest of this procedure must be completed within 1 minute and 30 seconds.

### 5 Handset:

Press **[OK]**, then wait until a long beep sounds and **[Y]** stops flashing.

- When the handset has been registered successfully, **[Y]** will stop flashing. If the key tone is turned on (page 29), a confirmation tone will be heard.

## Deregistering a handset

A handset can cancel its own registration (or the registration of another handset) that is stored in the base unit. This will allow the handset to end its wireless connection with the system.

- 1 **[MENU]** (centre of joystick) → **[↷]**  
→ **[SELECT]**
- 2 **[▼]/[▲]**: "Registration" → **[SELECT]**
- 3 **[▼]/[▲]**: "Deregistration" → **[SELECT]**
- 4 **[3][3][5]** → **[OK]**
  - The numbers of all handsets registered to the base unit are displayed.



## **Multi-unit Operation**

- 5** Select the handset(s) you want to cancel, by pressing the desired handset number ([1] – [6]). → **[OK]**
  - The selected handset number(s) flashes.
  - To cancel a selected handset number, press the number again. The number stops flashing.
- 6** [▼]/[▲]: “Yes” → **[SELECT]**
  - A long beep will sound as each handset number disappears.
- 7** After “Deregistered” is displayed, press **[OFF]**.

## Useful Information

### Belt clip

You can hang the handset on your belt or pocket using the supplied belt clip.

#### To attach the belt clip

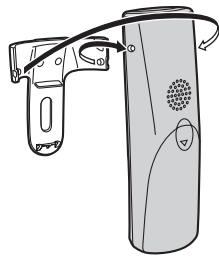

#### To remove the belt clip

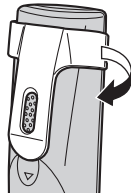

### Headset (optional)

Connecting a headset to the handset allows hands-free phone conversations. We recommend using the Panasonic headset noted on page 4.

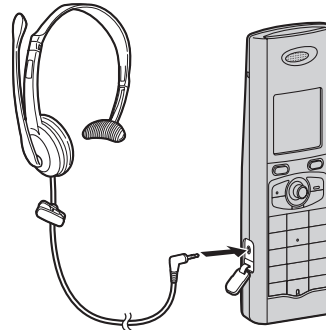

- Headset shown is RP-TCA86.

## Useful Information

### Error messages

If the unit detects a problem, one of the following messages is shown on the display.

Display message	Cause/solution
<b>Busy</b>	<ul style="list-style-type: none"> <li>• The called handset is in use.</li> <li>• The handset you are calling is too far from the base unit.</li> <li>• There is no handset registered to the base unit matching the extension number you entered.</li> <li>• Other units are in use and the system is busy. Try again later.</li> </ul>
<b>Error!!<sup>*1</sup></b>	<ul style="list-style-type: none"> <li>• Recording was too short. Try again.</li> </ul>
<b>Failed</b>	<ul style="list-style-type: none"> <li>• Phonebook copy failed. Confirm the other handset (the receiver) is in standby mode and try again.</li> </ul>
<b>Incomplete</b>	<ul style="list-style-type: none"> <li>• The receiver's phonebook memory is full. Erase the unnecessary phonebook entries from the other handset (the receiver) and try again.</li> </ul>
<b>Memory full</b>	<ul style="list-style-type: none"> <li>• The handset's phonebook memory is full. Erase unnecessary entries (page 21).</li> </ul>
<b>Messages full<sup>*1</sup></b>	<ul style="list-style-type: none"> <li>• Message memory becomes full. Erase unnecessary messages (page 33).</li> </ul>
<b>No items stored</b>	<ul style="list-style-type: none"> <li>• Your phonebook, caller list or redial list is empty.</li> </ul>
<b>No link to base. Move closer to base, try again.</b>	<ul style="list-style-type: none"> <li>• The handset has lost communication with the base unit. Move closer to the base unit and try again.</li> <li>• Unplug the base unit's AC adaptor to reset the unit. Reconnect the adaptor and try again.</li> <li>• The handset's registration may have been cancelled. Re-register the handset (page 40).</li> </ul>
<b>Please lift up and try again.</b>	<ul style="list-style-type: none"> <li>• A handset button was pressed while the handset was on the base unit or charger. Lift the handset and press the button again.</li> </ul>
<b>You must first subscribe to Caller ID.</b>	<ul style="list-style-type: none"> <li>• You must subscribe to Call Display service. Once you receive caller information after subscribing to Call Display service, this message will not be displayed.</li> </ul>

\*1 KX-TG8231/KX-TG8232

## Useful Information

### Troubleshooting

If you still have difficulties after following the instructions in this section, disconnect the base unit AC adaptor, then reconnect the base unit AC adaptor.

#### General use

Problem	Cause/solution
The unit does not work.	<ul style="list-style-type: none"> <li>• Make sure the batteries are installed correctly and fully charged (page 13).</li> <li>• Check the connections (page 12).</li> <li>• Unplug the base unit's AC adaptor to reset the unit. Reconnect the adaptor and try again.</li> <li>• The handset has not been registered to the base unit. Register the handset (page 40).</li> </ul>
I cannot hear a dial tone.	<ul style="list-style-type: none"> <li>• The base unit AC adaptor or telephone line cord is not connected. Check the connections.</li> <li>• If you are using a splitter to connect the unit, remove the splitter and connect the unit to the wall socket directly. If the unit operates properly, check the splitter.</li> <li>• Disconnect the unit from the telephone line and connect a known working telephone. If the working telephone operates properly, contact our service personnel to have the unit repaired. If the working telephone does not operate properly, contact your service provider/telephone company.</li> </ul>
I do not know how to erase "missed call" from the display.	<ul style="list-style-type: none"> <li>• There are unviewed missed calls remaining. View them using the following method.</li> </ul> <ol style="list-style-type: none"> <li>1 <b>[MENU]</b> (centre of joystick) → → <b>[SELECT]</b></li> <li>2 Push the joystick down to search from the most recent call, or push the joystick up to search from the oldest call.</li> </ol>



#### Programmable settings

Problem	Cause/solution
I have changed the display language to a language I cannot read.	<ul style="list-style-type: none"> <li>• Change the display language (page 15).</li> </ul>

**Useful Information**

Problem	Cause/solution
I cannot program items.	<ul style="list-style-type: none"> <li>• Programming is not possible while either the base unit or another handset is being used. Try again later.</li> </ul>
While programming, the handset starts to ring.	<ul style="list-style-type: none"> <li>• A call is being received. Answer the call and start again after hanging up.</li> </ul>
I cannot register a handset to a base unit.	<ul style="list-style-type: none"> <li>• The maximum number of handsets (6) is already registered to the base unit. Cancel unused handset registrations from the base unit (page 40).</li> <li>• Place the handset and the base unit away from other electrical appliances.</li> </ul>

**Battery recharge**

Problem	Cause/solution
The batteries should be charging but the battery icon does not change.	<ul style="list-style-type: none"> <li>• Clean the charge contacts and charge again (page 14).</li> </ul>
The handset beeps intermittently and/or  flashes.	<ul style="list-style-type: none"> <li>• Fully charge the batteries (page 14).</li> </ul>
I fully charged the batteries, but  still flashes.	<ul style="list-style-type: none"> <li>• Clean the charge contacts and charge again (page 14).</li> <li>• It is time to replace the batteries (page 13).</li> </ul>
I fully charged the batteries, but the operating time seems to be short.	<ul style="list-style-type: none"> <li>• Wipe the battery ends (+, -) and the unit contacts with a dry cloth.</li> </ul>
The handset display is blank.	<ul style="list-style-type: none"> <li>• The handset is in screen saver mode (page 15). Press <b>[OFF]</b> to activate the handset display again.</li> <li>• Confirm that the batteries are properly installed.</li> <li>• Fully charge the batteries (page 14).</li> </ul>

## Useful Information

### Making/answering calls, intercom

Problem	Cause/solution
⚡ is flashing.	<ul style="list-style-type: none"> <li>• The handset is not registered to the base unit. Register it (page 40).</li> <li>• The handset is too far from the base unit. Move closer.</li> <li>• The base unit AC adaptor is not connected. Check the connections.</li> <li>• You are using the handset or base unit in an area with high electrical interference. Place the handset and base unit away from interference sources, such as antennas and mobile phones.</li> </ul>
⚡ is displayed, but I cannot make a call.	<ul style="list-style-type: none"> <li>• The handset and base unit could not communicate for some reason, such as interference from other electrical appliances. Perform the following:                             <ul style="list-style-type: none"> <li>– Move the handset and base unit away from other electrical appliances.</li> <li>– Move closer to the base unit.</li> </ul> </li> </ul>
Static is heard, sound cuts in and out. Interference from other electrical units.	<ul style="list-style-type: none"> <li>• Place the handset and the base unit away from other electrical appliances.</li> <li>• Move closer to the base unit.</li> <li>• If your unit is connected to a telephone line with DSL service, we recommend connecting a noise filter between the base unit and the telephone line jack. Contact your DSL provider for details.</li> </ul>
Noise is heard during a call.	<ul style="list-style-type: none"> <li>• You are using the handset or base unit in an area with high electrical interference. Place the handset and base unit away from interference sources, such as antennas and mobile phones.</li> </ul>
The handset does not ring.	<ul style="list-style-type: none"> <li>• The ringer volume is turned off. Adjust the ringer volume (page 27, 28).</li> </ul>
I cannot make a call.	<ul style="list-style-type: none"> <li>• The dialing mode may be set incorrectly. Change the setting (page 16).</li> <li>• Another handset is in use or the answering system is being used. Wait and try again later.</li> </ul>
I cannot have a conversation using the headset.	<ul style="list-style-type: none"> <li>• Make sure that the optional headset is connected properly (page 42).</li> </ul>
I cannot make long distance calls.	<ul style="list-style-type: none"> <li>• Make sure that you have long distance service.</li> </ul>

**Useful Information**

Problem	Cause/solution
I cannot page the handset.	<ul style="list-style-type: none"> <li>• The called handset is too far from the base unit.</li> <li>• The called handset is in use. Try again later.</li> </ul>

**Call Display**

Problem	Cause/solution
The handset does not display the caller's name and/or phone number.	<ul style="list-style-type: none"> <li>• You have not subscribed to Call Display service. Contact your service provider/telephone company to subscribe.</li> <li>• If your unit is connected to any additional telephone equipment such as a Call Display box or cordless telephone line jack, disconnect the unit from the equipment and plug the unit directly into the wall jack.</li> <li>• If your unit is connected to a telephone line with DSL service, we recommend connecting a noise filter between the base unit and the telephone line jack. Contact your DSL provider for details.</li> <li>• The name display service may not be available in some areas. Contact your service provider/telephone company for details.</li> <li>• Other telephone equipment may be interfering with this unit. Disconnect the other equipment and try again.</li> <li>• The caller requested not to send caller information (page 24).</li> <li>• If a call is being transferred to you, the caller information is not displayed.</li> <li>• Generally, caller information is displayed from the 2nd ring.</li> </ul>
I cannot dial the phone number edited in the caller list.	<ul style="list-style-type: none"> <li>• The phone number you dialed might have been edited incorrectly (for example, the long distance "1" or the area code is missing). Edit the phone number with another pattern (page 25).</li> </ul>

**Useful Information**

Problem	Cause/solution
<p>The 2nd caller's information is not displayed during an outside call. (Visual Call Waiting feature does not function.)</p>	<ul style="list-style-type: none"> <li>● In order to use Call Display, Call Waiting, or Visual Call Waiting, you must first contact your service provider/telephone company and subscribe to the desired service. After subscribing, you may need to contact your service provider/telephone company again to activate this specific service, even if you already subscribed to both Call Display and Visual Call Waiting services.</li> </ul>

**Answering system (KX-TG8231/KX-TG8232)**

Problem	Cause/solution
<p>The unit does not record new messages.</p>	<ul style="list-style-type: none"> <li>● The answering system is off. Turn it on (page 31).</li> <li>● The message memory is full. Erase unnecessary messages (page 33).</li> <li>● If you subscribe to the voice mail service, messages are recorded by your service provider/telephone company not your telephone. Change the unit's "Ring count" setting or consult your service provider/telephone company (page 36).</li> </ul>
<p>I cannot operate the answering system with the handset.</p>	<ul style="list-style-type: none"> <li>● The base unit or another handset is being used. Wait for the other user to finish.</li> <li>● A caller is leaving a message. Wait for the caller to finish.</li> <li>● The handset is too far from the base unit. Move closer.</li> </ul>
<p>When I try to operate the answering system with the base unit, the ANSWER ON indicator on the base unit flashes for a few seconds and I cannot operate the answering system.</p>	<ul style="list-style-type: none"> <li>● Another handset is being used. Wait for the other user to finish.</li> <li>● A caller is leaving a message. Wait for the caller to finish.</li> </ul>



**Useful Information**

Problem	Cause/solution
I cannot operate the answering system remotely.	<ul style="list-style-type: none"><li>● You are entering the wrong remote access code. If you forget the remote access code, store a new remote access code again (page 36).</li><li>● Press each key firmly.</li><li>● The answering system is turned off. Turn it on (page 35).</li><li>● You are using a rotary/pulse telephone. Try again using a touch-tone phone.</li></ul>

## Useful Information

### Industry Canada Notices and other information

**NOTICE:**

This equipment meets the applicable Industry Canada Terminal Equipment Technical Specifications. This is confirmed by the registration number. The abbreviation, "IC:", before the registration number signifies that registration was performed based on a Declaration of Conformity indicating that Industry Canada technical specifications were met. It does not imply that Industry Canada approved the equipment.

And, the term "IC:" signifies that Industry Canada radio technical specifications were met.

Before installing this equipment, users should ensure that it is permissible to be connected to the facilities of the local telecommunications company. The equipment must also be installed using an acceptable method of connection. The customer should be aware that compliance with the above conditions may not prevent degradation of service in some situations.

Repairs to certified equipment should be coordinated by a representative designated by the supplier. Any repairs or alterations made by the user to this equipment, or equipment malfunctions, may give the telecommunications company cause to request the user to disconnect the equipment.

Users should ensure, for their own protection, that the electrical ground connections of the power utility, telephone lines and internal metallic water pipe system, if present, are

connected together. This precaution may be particularly important in rural areas.

**Caution:**

Users should not attempt to make such connections themselves, but should contact the appropriate electric inspection authority, or electrician, as appropriate.

**NOTICE:**

The **Ringer Equivalence Number (REN)** assigned to each terminal device provides an indication of the maximum number of terminals allowed to be connected to a telephone interface. The termination on an interface may consist of any combination of devices subject only to the requirement that the sum of the Ringer Equivalence Numbers of all the devices does not exceed 5.

The Ringer Equivalence Number (REN) of this unit:  
(found on the bottom of the unit).

**NOTICE:**

Operation is subject to the following two conditions: (1) this device may not cause interference, and (2) this device must accept any interference, including interference that may cause undesired operation of the device.

Privacy of communications may not be ensured when using this telephone.

Some cordless telephones operate at frequencies that may cause interference to nearby TVs and VCRs. To minimize or prevent such interference, the base of the cordless telephone should not be placed near, or on top of, a TV or VCR. If

## Useful Information

interference is experienced, move the cordless telephone further away from the TV or VCR. This will often reduce, or eliminate, interference.

### RF Exposure Warning:

- This product complies with IC radiation exposure limits set forth for an uncontrolled environment.
- To comply with IC RF exposure requirements, the base unit must be installed and operated 20 cm (8 inches) or more between product and all person's body (excluding extremities of hands, wrist and feet).
- This product may not be collocated or operated in conjunction with any other antenna or transmitter.
- The handset may be carried and operated with only the specific provided belt-clip. Other non-tested belt-clips or similar body-worn accessories may not comply and must be avoided.

## Useful Information

### Specifications

- **Standard:**  
DECT 6.0 (Digital Enhanced Cordless Telecommunications 6.0)
- **Number of channels:**  
60 Duplex Channels
- **Frequency range:**  
1.92 GHz to 1.93 GHz
- **Duplex procedure:**  
TDMA (Time Division Multiple Access)
- **Channel spacing:**  
1,728 kHz
- **Bit rate:**  
1,152 kbit/s
- **Modulation:**  
GFSK (Gaussian Frequency Shift Keying)
- **RF transmission power:**  
Approx. 100 mW
- **Voice coding:**  
ADPCM 32 kbit/s
- **Power source:**  
120 V AC, 60 Hz
- **Power consumption:**
  - Base unit<sup>\*1</sup>:**  
Standby: Approx. 1.7 W  
Maximum: Approx. 4.8 W
  - Base unit<sup>\*2</sup>:**  
Standby: Approx. 1.8 W  
Maximum: Approx. 5.0 W
  - Charger<sup>\*3</sup>:**  
Standby: Approx. 0.7 W  
Maximum: Approx. 3.5 W
- **Operating conditions:**  
5 °C – 40 °C (41 °F – 104 °F),  
20 % – 80 % relative air humidity (dry)
- **Dimensions:**
  - Base unit:** Approx. 44 mm × 116 mm × 113 mm  
(1 23/32 inches × 4 9/16 inches × 4 7/16 inches)

- Handset:** Approx. 143 mm × 47 mm × 32 mm  
(5 5/8 inches × 1 27/32 inches × 1 1/4 inches)
- Charger<sup>\*3</sup>:** Approx. 46 mm × 77 mm × 87 mm  
(1 13/16 inches × 3 1/32 inches × 3 7/16 inches)
- **Mass (weight):**
  - Base unit<sup>\*1</sup>:** Approx. 170 g (0.37 lb.)
  - Base unit<sup>\*2</sup>:** Approx. 190 g (0.42 lb.)
  - Handset:** Approx. 120 g (0.26 lb.)
  - Charger<sup>\*3</sup>:** Approx. 70 g (0.15 lb.)

- \*1 KX-TG8202
- \*2 KX-TG8231/KX-TG8232
- \*3 KX-TG8202/KX-TG8232

#### Note:

- Design and specifications are subject to change without notice.
- The illustrations in these instructions may vary slightly from the actual product.

**Useful Information**

---

## Warranty

**Panasonic Canada Inc.**

5770 Ambler Drive, Mississauga, Ontario L4W 2T3

**PANASONIC PRODUCT - LIMITED WARRANTY**

Panasonic Canada Inc. warrants this product to be free from defects in material and workmanship and agrees to remedy any such defect for a period as stated below from the date of original purchase.

**Telephone Accessory / Product - One (1) year, parts and labour**

**LIMITATIONS AND EXCLUSIONS**

This warranty does not apply to products purchased outside Canada or to any product which has been improperly installed, subjected to usage for which the product was not designed, misused or abused, damaged during shipping, or which has been altered or repaired in any way that affects the reliability or detracts from the performance, nor does it cover any product which is used commercially. Dry cell batteries are also excluded from coverage under this warranty. Rechargeable batteries are warranted for ninety (90) days from date of original purchase.

This warranty is extended to the original end user purchaser only. A purchase receipt or other proof of date of original purchase is required before warranty service is performed.

**THIS EXPRESS, LIMITED WARRANTY IS IN LIEU OF ALL OTHER WARRANTIES, EXPRESS OR IMPLIED, INCLUDING ANY IMPLIED WARRANTIES OF MERCHANTABILITY AND FITNESS FOR A PARTICULAR PURPOSE.**

**IN NO EVENT WILL PANASONIC CANADA INC. BE LIABLE FOR ANY SPECIAL, INDIRECT OR CONSEQUENTIAL DAMAGES.**

In certain instances, some jurisdictions do not allow the exclusion or limitation of incidental or consequential damages, or the exclusion of implied warranties, so the above limitations and exclusions may not be applicable.

**WARRANTY SERVICE**

**FOR PRODUCT OPERATION ASSISTANCE**, please contact:

Our Customer Care Centre: Telephone #: (905) 624-5505  
1-800 #: 1-800-561-5505  
Fax #: (905) 238-2360  
Email link: "Contact Us" on [www.panasonic.ca](http://www.panasonic.ca)

**FOR PRODUCT REPAIRS**, please locate your nearest Authorized Servicentre at [www.panasonic.ca](http://www.panasonic.ca) :

Link : "Servicentres™ locator" under "Customer support"

**IF YOU SHIP THE PRODUCT TO A SERVICENTRE**

Carefully pack and send prepaid, adequately insured and preferably in the original carton. Include details of the defect claimed, and proof of date of original purchase.

## Index

### Index

- A** Alarm: 30
- Answering calls: 18
- Answering system
  - Erasing messages: 33, 34, 35
  - Listening to messages: 33, 34, 35
  - Remote operation: 34
  - Settings: 36
  - Turning on/off: 31, 34, 35
- Auto talk: 18
- B** Battery: 13, 14
- Belt clip: 42
- C** Call Display service: 24
- Call privacy: 19
- Call screening: 31, 37
- Call share: 19
- Call Waiting: 18
- Caller list: 25
- Caller list edit: 25
- Chain dial: 22
- Conference calls: 39
- Connections: 12
- Customer support: 30
- D** Daily alarm: 30
- Date and time: 16
- Deregistration: 40
- Dialing mode: 16
- Display
  - Colour: 27, 28
  - Contrast: 27, 28
  - Language: 15
  - Wallpaper: 27, 28
- E** Error messages: 43
- F** Flash: 18
- Flash time: 29
- G** Greeting message: 32
- Group
  - Display colours: 25
  - Ringer tones: 24
- H** Handset locator: 39
- Headset, optional: 4, 42
- I** Intercom: 39
- K** Key tone: 29
- M** Making calls: 17
- Memory capacity (message recording): 31
- Missed calls: 24
- Mute: 18
- O** One touch dial: 22
- P** Pause: 17
- Phonebook: 20
- Phonebook copy: 23
- Power failure: 12
- Pulse service: 18
- R** Recording time: 36
- Redial list: 17
- Registration: 40
- Remote code: 36
- Remote command: 35
- Remote operation: 34
- Ring count: 36
- Ringer off: 18, 27, 28
- Ringer tone: 27, 28
- Rotary service: 18
- S** Soft keys: 11
- SP-PHONE (Speakerphone): 17
- T** Time adjustment: 27
- Toll saver: 36
- Tone: 16, 18
- Transferring calls: 39
- Troubleshooting: 44
- V** Visual Call Waiting: 24
- Voice guidance: 34
- Voice guidance language: 16
- Voice Mail: 36, 38
- Volume
  - Handset ringer: 27, 28
  - Receiver: 11, 17
  - Speaker: 11, 17
- W** Warranty: 53

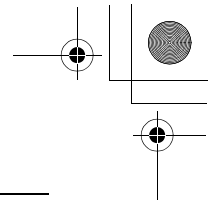
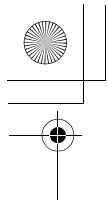

---

**Notes**

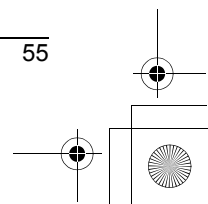
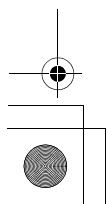
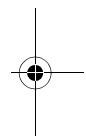
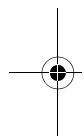

We recommend keeping a record of the following information for future reference.

Serial No. \_\_\_\_\_ Date of purchase \_\_\_\_\_  
(found on the bottom of the base unit)

Name and address of dealer \_\_\_\_\_

-----  
[ **Attach your purchase receipt here.** ]  
-----

**Panasonic Canada Inc.**  
5770 Ambler Drive, Mississauga, Ontario L4W 2T3

**Copyright:**  
This material is copyrighted by Panasonic Communications Co., Ltd., and may be reproduced for internal use only. All other reproduction, in whole or in part, is prohibited without the written consent of Panasonic Communications Co., Ltd.  
© 2007 Panasonic Communications Co., Ltd. All Rights Reserved.



\*TG8231C\*

**PQQX16370ZA** DC0707YK0