

# Panasonic®

Model No.  
TC-L24X5  
TC-L24X5X

## Owner's Manual LCD Television



# VIERA

### English

Thank you for purchasing this Panasonic product.  
Please read these instructions before operating your set and retain them for future reference. The images shown in this manual are for illustrative purposes only.

### Español

Gracias por su decisión de comprar este producto marca Panasonic.  
Lea estas instrucciones antes de utilizar su televisor y guárdelas para consultarlas en el futuro. Las imágenes mostradas en este manual tienen solamente fines ilustrativos.

## Contents

|  |           |
|--|-----------|
| <b>SAFETY PRECAUTIONS</b> .....                    | <b>3</b>  |
| Note to CATV System Installer .....                | 3         |
| Secure Ventilation .....                           | 3         |
| Important Safety Instructions (TV set) .....       | 3         |
| <b>FCC STATEMENT</b> .....                         | <b>5</b>  |
| FCC warning .....                                  | 5         |
| Cables .....                                       | 5         |
| Canadian notice .....                              | 5         |
| <b>CEA CHILD SAFETY NOTICES</b> .....              | <b>5</b>  |
| <b>Standard Accessories</b> .....                  | <b>6</b>  |
| <b>Attaching the Pedestal</b> .....                | <b>6</b>  |
| Installing Pedestal .....                          | 7         |
| Uninstalling Pedestal .....                        | 7         |
| Wall-hanging (Not supplied).....                   | 7         |
| <b>PART NAMES AND FUNCTIONS</b> .....              | <b>8</b>  |
| TV Controls/ Indicators.....                       | 8         |
| TV (Side / Back).....                              | 8         |
| <b>Connections</b> .....                           | <b>9</b>  |
| Computer Connection.....                           | 9         |
| Video Equipment Connection .....                   | 9         |
| AC Power Cord Connection .....                     | 10        |
| Antenna or Cable Connection .....                  | 10        |
| <b>Remote Control Batteries Installation</b> ..... | <b>10</b> |
| <b>Remote Control</b> .....                        | <b>11</b> |
| <b>Turning On/Off LCD TV</b> .....                 | <b>12</b> |
| <b>Selecting Input Source</b> .....                | <b>12</b> |
| <b>ASPECT</b> .....                                | <b>12</b> |
| <b>Turning on your TV for the first time</b> ..... | <b>12</b> |
| <b>On-Screen Display</b> .....                     | <b>13</b> |
| Picture .....                                      | 13        |
| Audio .....  | 14        |
| Lock .....   | 15        |
| TV .....   | 16        |
| Setup.....   | 17        |
| Media Player.....                                  | 18        |
| <b>TROUBLESHOOTING</b> .....                       | <b>19</b> |
| <b>SPECIFICATIONS</b> .....                        | <b>20</b> |
| <b>Input Signal Compatibility Chart</b> .....      | <b>21</b> |
| COMPONENT (Y, PB, PR), HDMI.....                   | 21        |
| PC (from D-sub terminal/ HDMI terminal).....       | 21        |
| <b>Multi-media Supported Specification</b> .....   | <b>22</b> |
| Photos.....  | 22        |
| Music.....   | 22        |
| Videos.....  | 22        |
| <b>LICENSE</b> .....                               | <b>23</b> |

## SAFETY PRECAUTIONS

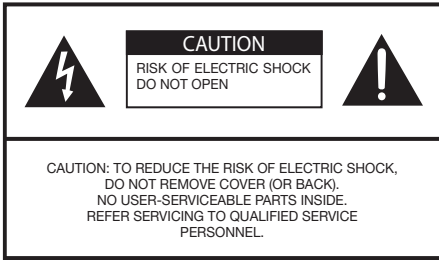

|  |  |
|--|--|
|  | The lightning flash with arrowhead within a triangle is intended to tell the user that parts inside the product are a risk of electric shock to persons.       |
|  | The exclamation point within a triangle is intended to tell the user that important operating and servicing instructions are in the papers with the appliance. |

### Note to CATV System Installer

This reminder is provided to direct the CATV system installer's attention to Article 820-40 of the NEC that provides guidelines for proper grounding and, in particular, specifies that the cable ground shall be connected to the grounding system of the building, as close to the point of cable entry as practical.

### Secure Ventilation

Slots and openings in the cabinet and the back or bottom are provided for ventilation, and to ensure reliable operation of the LCD TV and to protect it from overheating. These openings must not be blocked or covered. There should be at least 10 cm of space around the TV. The openings should never be blocked by placing the LCD TV on a bed, sofa, rug or other similar surface. This LCD TV should not be placed in a built-in installation such as a bookcase unless proper ventilation is provided.

## Important Safety Instructions (TV set)

1. Read these instructions.
2. Keep these instructions.
3. Heed all warnings.
4. Follow all instructions.
5. Do not use this apparatus near water.
6. Clean only with dry cloth.
7. Do not block any ventilation openings. Install in accordance with the manufacturer's instructions.
8. Do not install near any heat sources such as radiators, heat registers, stoves, or other apparatus (including amplifiers) that produce heat.
9. Do not defeat the safety purpose of the polarized or grounding-type plug. A polarized plug has two blades with one wider than the other. A grounding type plug has two blades and a third grounding prong. The wide blade or the third prong are provided for your safety. If the provided plug does not fit into your outlet, consult an electrician for replacement of the obsolete outlet.
10. Protect the power cord from being walked on or pinched particularly at plugs, convenience receptacles, and the point where they exit from the apparatus.
11. Only use attachments/accessories specified by the manufacturer.
12. Use only with the cart, stand, tripod, bracket, or table specified by the manufacturer, or sold with the apparatus. When a cart is used, use caution when moving the cart/apparatus combination to avoid injury from tip-over.
13. Unplug this apparatus during lightning storms or when unused for long periods of time.
14. Refer all servicing to qualified service personnel. Servicing is required when the apparatus has been damaged in any way, such as power-supply cord or plug is damaged, liquid has been spilled or objects have fallen into the apparatus, the apparatus has been exposed to rain or moisture, does not operate normally, or has been dropped.
15. Operate only from the type of power source indicated on the marking label. If you are not sure of the type of power supplied to your home consult your television dealer or local power company.
16. Follow all warnings and instructions marked on the LCD TV.
17. Never push objects of any kind into this LCD TV through cabinet slots as they may touch dangerous voltage points or short out parts that could result in a fire or electric shock. Never spill liquid of any kind on the LCD TV.
18. If an outside antenna is connected to the television equipment, be sure the antenna system is grounded so as to provide some protection against voltage surges and built up static charges. In the U.S. Section 810-21 of the National Electrical Code provides information with respect to proper grounding of the mast and supporting structure, grounding of the lead-in wire to an antenna discharge unit, size of grounding conductors, location of antenna discharge unit, connection to grounding electrodes, and requirements for the grounding electrode.



EXAMPLE OF ANTENNA GROUNDING AS PER NATIONAL ELECTRICAL CODE, ANSI/NFPA 70

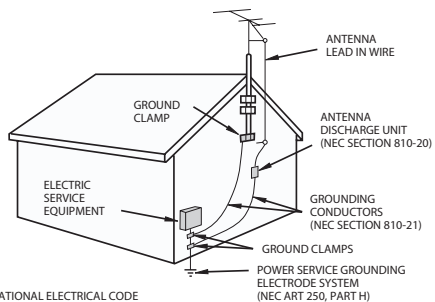

NEC — NATIONAL ELECTRICAL CODE

19. An outside antenna system should not be located in the vicinity of overhead power lines, other electric light, power circuits, or where it can fall into such power lines or circuits. When installing an outside antenna system, extreme care should be taken to keep from touching such power lines or circuits as contact with them might be fatal.
20. Unplug this LCD TV from the wall outlet and refer servicing to qualified service personnel under the following conditions:
  - a. When the power cord or plug is damaged or frayed.
  - b. If liquid has been spilled into the LCD TV.
  - c. If the LCD TV has been exposed to rain or water.
  - d. If the LCD TV does not operate normally by following the operating instructions.  
Adjust only those controls that are covered by the operating instructions as improper adjustment of other controls may result in damage and will often require extensive work by a qualified technician to restore the LCD TV to normal operation.
  - e. If the LCD TV has been dropped or the cabinet has been damaged.
  - f. When the LCD TV exhibits a distinct change in performance - this indicates a need for service.
21. When replacement parts are required, be sure the service technician uses replacement parts specified by the manufacturer that have the same characteristics as the original parts. Unauthorized substitutions may result in fire, electric shock, or other hazards.
22. **WARNING:**  
TO REDUCE THE RISK OF FIRE OR ELECTRIC SHOCK, DO NOT EXPOSE THIS APPARATUS TO RAIN, MOISTURE, DRIPPING OR SPLASHING. DO NOT PLACE LIQUID CONTAINERS (FLOWER VASES, CUPS, COSMETICS, ETC.) ABOVE THE SET (INCLUDING ON SHELVES ABOVE, ETC.).
23. **WARNING:**  
APPARATUS SHALL NOT BE EXPOSED TO DRIPPING OR SPLASHING AND NO OBJECTS FILLED WITH LIQUIDS, SUCH AS VASES, SHALL BE PLACED ON THE APPARATUS.
24. **WARNING:**  
SMALL PARTS CAN PRESENT CHOKING HAZARD IF ACCIDENTALLY SWALLOWED. KEEP SMALL PARTS AWAY FROM YOUNG CHILDREN. DISCARD UNNEEDED SMALL PARTS AND OTHER OBJECTS, INCLUDING PACKAGING MATERIALS AND PLASTIC BAGS/SHEETS TO PREVENT THEM FROM BEING PLAYED WITH BY YOUNG CHILDREN, CREATING THE POTENTIAL RISK OF SUFFOCATION.

**25. WARNING:**

To prevent the spread of fire, keep candles or other open flames away from this product at all times.



**26. CAUTION:**

The Power switch on this unit will not completely shut off all power from AC outlet. Since the power cord serves as the main disconnect device for the unit, you will need to unplug it from the AC outlet to shut down all power. Therefore, make sure the unit has been installed so that the power cord can be easily unplugged from AC outlet in case of an accident. To avoid fire hazard, the power cord should also be unplugged from the AC outlet when left unused for a long period of time (for example, when on vacation).

**27. CAUTION:**

TO PREVENT ELECTRIC SHOCK, DO NOT USE THIS PLUG WITH A RECEPTACLE OR OTHER OUTLET UNLESS THE BLADES CAN BE FULLY INSERTED TO PREVENT BLADE EXPOSURE.

**28. CAUTION:**

USE WITH OTHER STAND MAY RESULT IN INSTABILITY POSSIBLY CAUSING INJURY.

**29. CAUTION:**

DANGER OF EXPLOSION IF BATTERY IS INCORRECTLY REPLACED. REPLACE ONLY WITH THE SAME OR EQUIVALENT TYPE.

**30. CAUTION:**

This LCD TV is for use only with the following optional accessory. Use with any other type of optional accessories may cause instability which could result in the possibility of injury.

**31. CAUTION:**

These servicing instructions are for use by qualified service personnel only. To reduce the risk of electric shock, do not perform any servicing other than that contained in the operating instructions unless you are qualified to do so.

**Note:**

This equipment is designed to operate in North America and other countries where the broadcasting system and AC house current are exactly the same as in North America.

## FCC STATEMENT

This equipment has been tested and found to comply with the limits for a Class B digital device, pursuant to Part 15 of the FCC Rules. These limits are designed to provide reasonable protection against harmful interference in a residential installation. This equipment generates, uses and can radiate radio frequency energy and, if not installed and used in accordance with the instructions, may cause harmful interference to radio communications. However, there is no guarantee that interference will not occur in a particular installation. If this equipment does cause harmful interference to radio or television reception, which can be determined by turning the equipment off and on, the user is encouraged to try to correct the interference by one or more of the following measures:

- Reorient or relocate the receiving antenna.
- Increase the separation between the equipment and receiver.
- Connect the equipment into an outlet on a circuit different from that to which the receiver is connected.
- Consult the Panasonic Service Center or an experienced radio/TV technician for help.

**FCC Caution: To assure continued compliance, follow the attached installation instructions and use only shielded interface cable when connecting to computer or peripheral devices. Any changes or modifications not expressly approved by Panasonic Corp. of North America could void the user's authority to operate this device.**

### FCC Declaration of Conformity

|                    |   |
|--------------------|---|
| Models:            | TC-L24X5/TC-L24X5X  |
| Responsible Party: | Panasonic Corporation of North America<br>One Panasonic Way, Secaucus, NJ 07094 |
| Contact Source:    | Panasonic Consumer Marketing Company<br>of North America                        |
| Telephone No.:     | 1-877-95-VIERA (958-4372)   |
| Email:             | consumerproducts@panasonic.com  |

This device complies with Part 15 of the FCC Rules. Operation is subject to the following two conditions: (1) This device may not cause harmful interference, and (2) this device must accept any interference received, including interference that may cause undesired operation.

## FCC warning

Changes or modifications not expressly approved by the party responsible for compliance with the FCC Rules could void the user's authority to operate this equipment.

## Cables

Connections to this device must be made with shielded cables with metallic RF/EMI connector hoods to maintain compliance with FCC Rules and Regulations.

## Canadian notice

This Class B digital apparatus complies with Canadian ICES-003.

Cet appareil numérique de la classe B est conforme à la norme NMB-003 du Canada.

"Standard Television Receiving Apparatus-Appareil de réception télévision ordinaire, Canada BETS-7 / NTMR-7".

## CEA CHILD SAFETY NOTICES

### Warning

Flat panel displays are not always supported on the proper stands or installed according to the manufacturer's recommendations. Flat panel displays that are inappropriately situated on dressers, bookcases, shelves, desks, speakers, chests or carts may fall over and may cause personal injury or even death.

The consumer electronics industry (of which Panasonic is a member) is committed to making home entertainment enjoyable and safe. To prevent personal injury or death, be sure to follow the following safety guidelines:

### TUNE INTO SAFETY:

- One size does NOT fit all. Follow the manufacturer's recommendations for the safe installation and use of your flat panel display.
- Carefully read and understand all enclosed instructions for proper use of this product.
- Don't allow children to climb on or play with furniture and television sets.
- Don't place flat panel displays on furniture that can easily be used as steps, such as a chest of drawers.
- Remember that children can become excited while watching a program, especially on "larger than life" flat panel displays. Care should be taken to install the display where it cannot be pushed, pulled over, or knocked down.
- Care should be taken to route all cords and cables connected to the flat panel display so that they cannot be pulled or grabbed by curious children.

### WALL MOUNTING:

IF YOU DECIDE TO WALL MOUNT YOUR FLAT PANEL DISPLAY, ALWAYS:

- Use a mount that has been recommended by the display manufacturer and/or listed by an independent laboratory (such as UL, CSA, ETL).
- Follow all instructions supplied by the display and wall mount manufacturers.
- If you have any doubts about your ability to safely install your flat panel display, contact your retailer about professional installation.
- Make sure the wall where you are mounting the display is appropriate. Some wall mounts are not designed to be mounted to walls with steel studs or old cinder block construction. If you are unsure, contact a professional installer.
- A minimum of two people are required for installation. Flat panel displays can be heavy.

**Panasonic recommends that a qualified installer perform the wall-mount installation.**

The American Academy of Pediatrics discourages media viewing for children younger than two years. For more details, see [www.aap.org](http://www.aap.org).

## Standard Accessories

Check you have all the items shown.

Remote Control  
(TZ200000005A)



Batteries (AAA) x 2  
(392GB1TX1A32GP)



Neck and Base  
(Neck: X34T0059AFL01L0100  
Base: X34T0060AFL01L01BA)

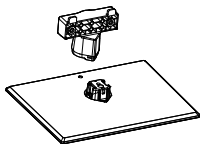

Screws x 3  
(Assembly screws for neck and  
base)  
(0Q1G 940 18 47 CR3)



Power Cord  
(089G202A15N HL  
/089G202A15N JR)

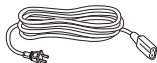

## Attaching the Pedestal

### Warning

**Do not disassemble or modify the pedestal.**

- Otherwise the TV may fall over and become damaged, and personal injury may result.

### Caution

**Do not use any pedestal other than that provided with this TV.**

- Otherwise the TV may fall over and become damaged, and personal injury may result.

**Do not use the pedestal if it becomes warped or physically damaged.**

- If you use the pedestal while it is physically damaged, personal injury may result. Contact your nearest Panasonic dealer immediately.

**During assembly, use only screws supplied and make sure that all screws are securely tightened.**

- If sufficient care is not taken to ensure screws are properly tightened during assembly, the pedestal will not be strong enough to support the TV. It might fall over and become damaged and personal injury may result.

**Ensure that the TV does not fall over.**

- If the TV is knocked or children climb onto the pedestal with the TV installed, the TV may fall over and personal injury may result.

**Two or more people are required to install and remove the TV.**

- If two or more people are not present, the TV may be dropped, and personal injury may result.

## Installing Pedestal

1. Place the LCD TV screen facing down on a flat surface place where maintained with soft materials (such as a blanket) for protecting the display screen.
2. Use the assembly screw to fasten the neck to the base securely.

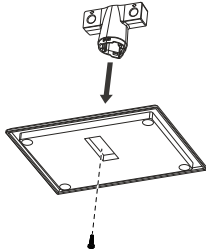

3. Use only the supplied assembly screws to fasten the pedestal securely to the TV.

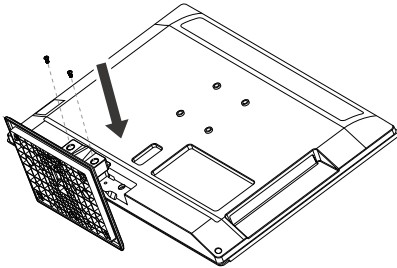

## Uninstalling Pedestal

1. Place the LCD TV screen facing down on a flat surface place where maintained with soft materials (such as a blanket) for protecting the display screen.
2. Remove screws in two holes with screw driver.

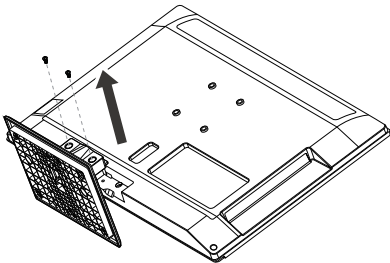

## Wall-hanging (Not supplied)

### Wall-hanging Insets

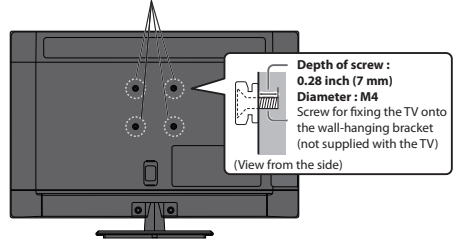

VESA standard interface

2.95 x 2.95 inch (75 x 75 mm)

### Wall-hanging bracket (Optional)

Please contact your nearest Panasonic dealer to purchase the recommended optional accessories.

For additional details, please refer to the manual of the optional accessories.

### Warning

- Using other wall-hanging brackets, or installing a wall hanging bracket by yourself have the risk of personal injury and product damage. In order to maintain the unit's performance and safety, be absolutely sure to ask your dealer or a licensed contractor to secure the wall-hanging brackets. Any damage caused by installing without a qualified installer will void your warranty.
- Do not mount the unit directly below ceiling lights (such as spotlights, floodlights or halogen lights) which typically give off high heat. Doing so may warp or damage plastic cabinet parts.
- Take care when fixing wall brackets to the wall. Always ensure that there are no electrical cables or pipes in the wall before hanging bracket.
- To prevent fall and injury, remove the TV from its fixed wall position when it is no longer in use.

# PART NAMES AND FUNCTIONS

## TV Controls/ Indicators

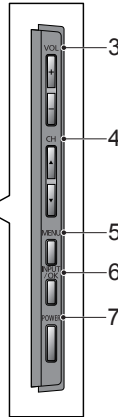
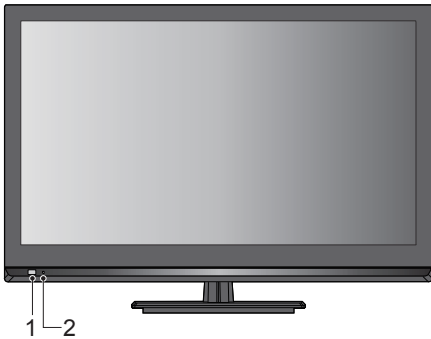

### 1 Remote Control Signal Receiver

- Do not place any objects between the TV remote control signal receiver and remote control.

### 2 Power indicator

**On:** Power indicator lights Red.

**Standby:** Power indicator turns off.

### 3 VOL +/-

- Used to change volume.
- Used to adjust the value of the selected item on On-Screen Menu.

### 4 CH ▲/▼

- Used to change channels.
- Used to select item on On-Screen Menu.

### 5 MENU

- Open or close the On-Screen Menu.

### 6 INPUT/OK

- Use to select an input source.
- Confirm and enter a selection.

### 7 POWER

- Use to turn the TV On or Off.

## TV (Side / Back)

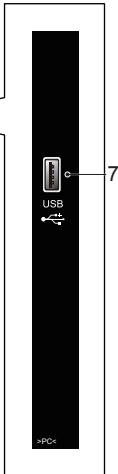
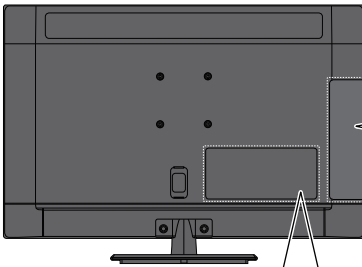

### 1 HDMI

- Connect all kinds of HDMI output equipment.

### 2 VIDEO IN

- Connect video and audio output from video equipment.

### 3 AUDIO IN

- Connect the audio for a computer or a DVI device.

### 4 DIGITAL AUDIO OUT

- Connect an audio amplifier to this jack.

### 5 PC

- Connect computer outputs to this terminal.
- Connect an audio cable to AUDIO IN and audio out jack on the computer.

### 6 ANTENNA/CABLE IN

- Connect an antenna or cable TV.

### 7 USB

- Connect USB memory to this terminal to play Multimedia.

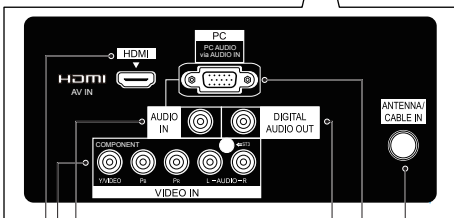

1 2 3

4 5 6



# Connections

## Computer Connection

Cable used for connection (This cable is not supplied with this LCD TV.)

- PC/VGA Cable (D-SUB 15pin)
- Audio Cable

**Note:**

When connecting the cable, AC Power Cords of both LCD TV and external equipment should be disconnected from AC outlet. Turn LCD TV and peripheral equipment on before your computer is switched on.

**Note:**

You can connect the DVI source to HDMI input terminal by using the DVI to HDMI converter then connect audio input to PC audio input terminal.

## Video Equipment Connection

Cables used for connection (These cables are not supplied with this LCD TV.)

- Component/Video, Audio Cable
- HDMI Cable: HDMI Input
- Digital audio cable

**Note:**

When connecting the cable, AC Power Cords of both LCD TV and external equipment should be disconnected from AC outlet.

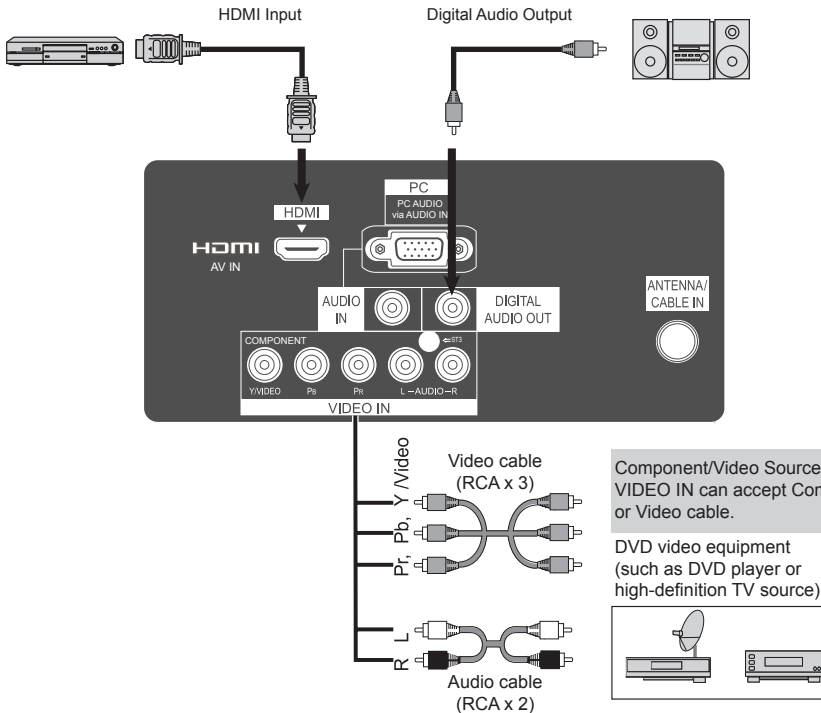

**Note:**

- AUDIO IN: Connect the audio for a computer or a DVI device.
- DIGITAL AUDIO OUT: Connect an audio amplifier to this jack.

## AC Power Cord Connection

This LCD TV uses nominal input voltages of 110-127V AC. It is designed to work with single-phase power systems. To reduce risk of electrical shock, do not plug into any other type of power system. Consult your authorized dealer or service station if you are not sure the type of power being supplied. Connect the LCD TV with all peripheral equipment before turning the LCD TV on.

### Caution

- For safety, unplug AC power cord when the LCD TV is not in use.

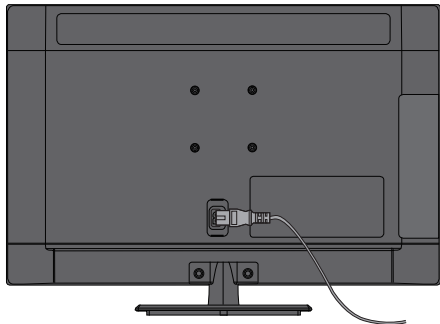

## Antenna or Cable Connection

Cable used for connection (This Outdoor Aerial cable is not supplied with this LCD TV.)

- Aerial Cable

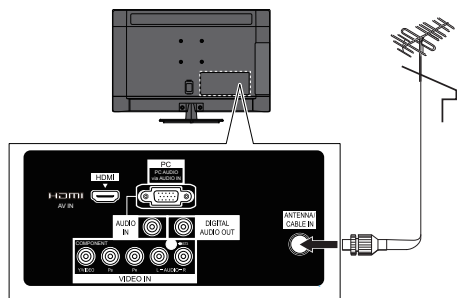

### Note:

- ATSC is not available except in U.S.A., Canada, and/or Mexico.
- For all aerial circuit problems, please consult your local dealer.

## Remote Control Batteries Installation

1. Remove the battery compartment cover.

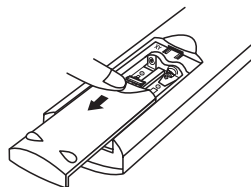

2. Insert two size AAA batteries (1.5V) according to "+" and "-" polarity markings inside the battery compartment.

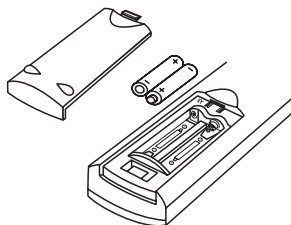

3. Close the battery compartment cover.

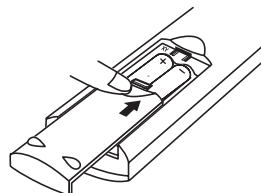

### Caution

To insure safe operation, please observe the following precautions:

- Replace two batteries at the same time.
- Do not use a new battery with a used battery.
- Avoid contacting with water or liquid.
- Do not expose the Remote Control or Batteries to moisture, or heat such as sunshine, fire or the like.
- Do not drop the Remote Control.
- If a battery has leaked on the Remote Control, carefully wipe case clean and install new batteries.
- Risk of explosion if battery is replaced by an incorrect type.
- Dispose of used batteries according to the instructions.
- Remote control contains AAA battery and must be kept out of reach of small children to avoid accidental ingestion.

## Remote Control

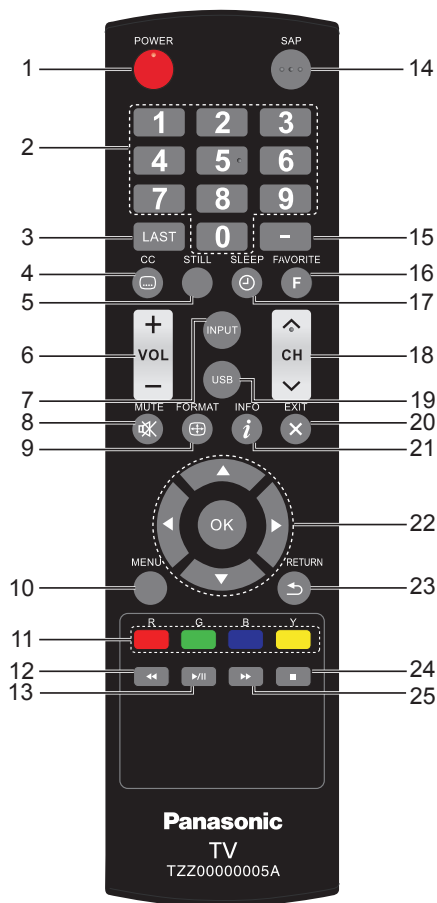

### 1 Standby On / Off switch

- Switches TV On or Off standby.

### 2 Numeric buttons

- Changes channel.

### 3 LAST

- Switches to previously viewed channel.

### 4 CC

- Changes to next closed caption selection.

### 5 STILL

- Press to freeze a moving image on the screen.

### 6 VOL +/-

- Press to adjust the volume.

### 7 INPUT

- Opens input source list.

### 8 MUTE

- Press to mute or restore the sound.

### 9 FORMAT

- Changes aspect ratio.

- Also possible by pressing this button repeatedly until you reach the desired aspect.

### 10 MENU

- Open or close the On-Screen Menu.

### 11 R/G/B/Y (COLOR BUTTON)

- Used for the selection, navigation and operation of various functions.

### 12 ◀◀

- Fast reverse for multi-media playback.

### 13 ▶/II

- Play or pause for multi-media playback.

### 14 SAP (Secondary Audio Programming)

- Selects the audio mode for watching TV.

### 15 —

- Use for digital channels.

- Press to enter the minor number in a compound channel number.

### 16 FAVORITE

- Open the favorite channel list.

### 17 SLEEP

- Sets the time settings of off timer.

### 18 CH ^ / V

- Selects channel in sequence.

### 19 USB

- Switches to USB input source.

### 20 EXIT

- Returns to the normal viewing screen.

### 21 INFO

- Displays channel and program information.

### 22 ▲/▼/◀/▶/OK

- Confirms selections and choices.

### 23 RETURN

- Go back to previous menu.

### 24 ■

- Stop for multi-media playback.

### 25 ▶▶

- Fast forward for multi-media playback.

## Turning On/Off LCD TV

1. Complete the peripheral connections before turning on LCD TV.
2. Connect LCD TV's AC Power Cord into an AC outlet.
3. Press POWER button on Side Control of LCD TV or use Remote Control to turn it ON.  
The POWER indicator will light up (Red).
4. Press POWER button again to enter stand-by status, the POWER indicator will be turned off.

## Selecting Input Source

Press **INPUT** button of Remote Control or Side Control to select mode **TV**, **Video**, **HDMI**, or **PC**.  
Press **USB** button of Remote Control to enter USB content.

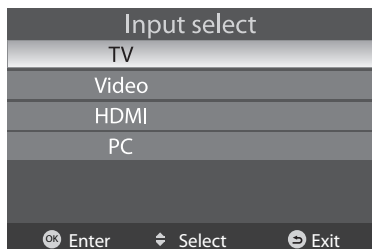

## ASPECT

Selects screen size among "Just", "Zoom", "Full", "4:3", or "H-Fill" by pressing **FORMAT** button on Remote Control.

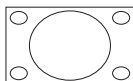

[Just]  
Stretches to justify the 4:3 image to the four corners of the screen.

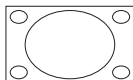

[Full]  
Enlarges the 4:3 image horizontally to the screen's side edges.

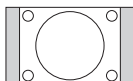

[4:3]  
Displays the image at the standard 4:3 without distortion.



[Zoom]  
Enlarges the 4:3 image to the entire screen.



[H-Fill]  
Enlarges the 4:3 image horizontally to the screen's side edges. The side edges of the image are cut off.

### Note:

- 480i(4:3)/480p(4:3):  
Full, JUST, 4:3, Zoom
- 720p(16:9)/1080i(16:9)/1080p(16:9):  
Full, H-Fill, 4:3, JUST, Zoom

## Turning on your TV for the first time

### 1 Language setting

- Selects OSD menu language from English, Spanish, or French.

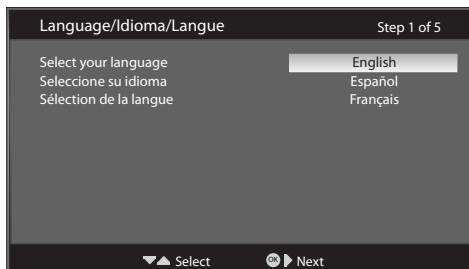

### 2 Viewing mode

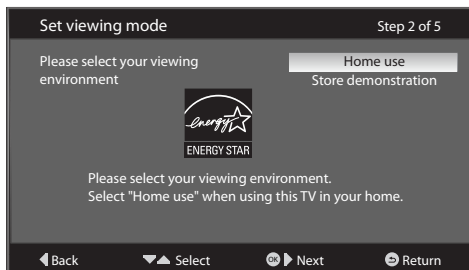

### Note:

- If you selected **Store demonstration**, a message asks you to confirm your selection. Select **Yes** to continue, or select **No** to change your viewing mode.
- **Store demonstration** is not an energy-saving mode.

### 3 Tuner setting

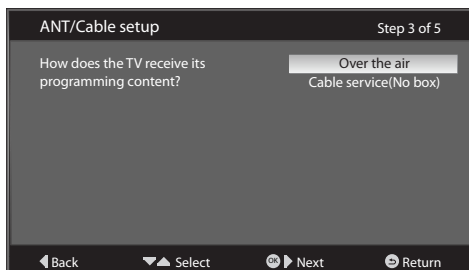

## 4 Channel scan setting

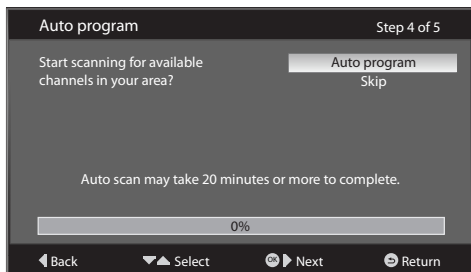

## 5 Start channel searching

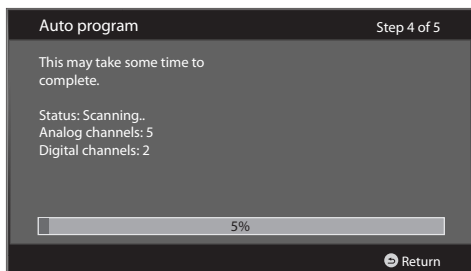

## 6 Initial setup completed

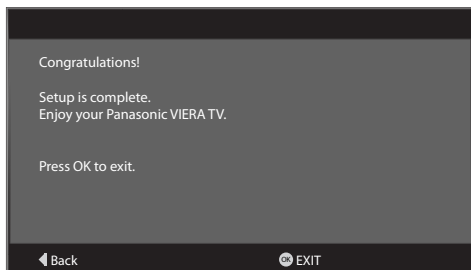

## On-Screen Display

### Picture

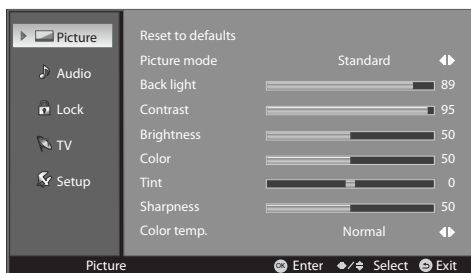

1. Press **MENU** button and **▲▼** buttons to select "Picture", the Picture menu will be displayed.
2. Press **OK** button to enter Picture menu.
3. Press **▲▼** buttons to select item desired.
4. Press **◀▶** buttons to adjust value.
5. Press **RETURN** button to return the previous menu.
6. Press **EXIT** button to exit menu operation.

### Reset to defaults

- Resets all picture adjustments to factory default settings for current Picture mode.

### Picture mode

- Basic picture mode **Vivid** / **Standard** / **Cinema** / **Game** / **Custom**.

#### Vivid

- Provides enhanced picture contrast and sharpness for viewing in a well-lit room.

#### Standard

- Recommended for normal viewing conditions with subdued room lighting.

#### Cinema

- For watching movies in a darkened room with the improved performance of contrast, black and color reproduction.

#### Game

- Fast response signal specifically to provide suitable images for playing games.

#### Custom

- Sets the settings for your preferred.

### Back light

- Adjusts the luminance of the back light. (0~100)

### Contrast

- Increases or decreases the levels of contrast according to your personal preference. (0~100)

### Brightness

- Increases or decreases the levels of brightness according to your personal preference. (0~100)

## Color

- Increases or decreases the levels of color according to your personal preference. (0~100)

## Tint

- With an NTSC signal source connected to the TV, the picture hue can be adjusted to suit your taste. (-50~50)
- For NTSC signal reception only.

## Sharpness

- Increases or decreases the levels of sharpness according to your personal preference. (0~100)

## Color temp.

- Allows you to set the overall color tone of the picture **Cool/Normal/Warm**.

## A.I. picture

- Controls dark areas without affecting the black level or brightness in the overall picture.

## Video NR

- Reduces noise, commonly called snow. Leave it off when receiving a strong signal.

## Advanced picture

- Provides various advanced settings for improving the picture quality.

### 3D Y/C filter

- Minimizes noise and cross-color in the picture.

### Color matrix

- Selects image resolution of component-connected devices.

### Black level

- Selects Dark or Light. Valid only for external input signals.

### MPEG NR

- Reduced a grained noise when receiving MPEG signal.

### 3:2 pulldown

- Adjusts the picture recorded in 24 fps for optimum quality.

### Aspect adjustments

- Screen format:** Changes the format (aspect ratio). Lets you choose the aspect depending on the format of received signal.
- H size:** Adjusts the horizontal display range to reduce noise of both side edges of an image.
- Zoom adjustments:** Adjusts vertical alignment and size when aspect setting is **ZOOM**.

## PC adjustments

- For PC input source only.

### Auto Adjust

- Adjusts the position and phase automatically.

### H.position

- Adjusts the horizontal position.

### V.position

- Adjusts the vertical position.

### Phase

- Adjusts the focus of stable images.

### Clock

- Adjusts the sample frequency.

## Audio

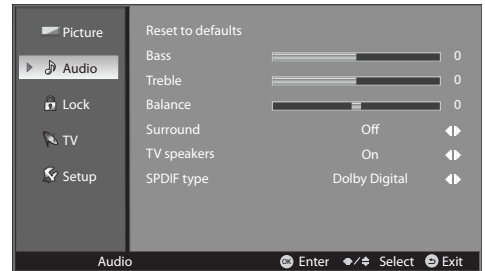

- Press **MENU** button and **▲▼** buttons to select "Audio", the Audio menu will be displayed.
- Press **OK** button to enter Audio menu.
- Press **▲▼** buttons to select item desired.
- Press **◀▶** buttons to adjust value.
- Press **RETURN** button to return the previous menu.
- Press **EXIT** button to exit menu operation.

## Reset to defaults

- Resets Bass, Treble, and Balance adjustments to factory default settings.

## Bass

- Increases or decreases level to enhance or minimize lower, deeper sound output. (-14~14)

## Treble

- Increases or decreases level to enhance or minimize sharper, higher sound output. (-14~14)

## Balance

- Adjusts volume level of right and left speakers. (-50~50)

## Surround

- Enriches (expanding and deepening) the sound quality.

## TV speakers

- Selects to turn on or off the TV internal speaker.

### Off

- Turns the TV internal speaker off.

### On

- Turns the TV internal speaker on.

## SPDIF type

- Selects the initial setting for digital audio output signal from DIGITAL AUDIO OUT and HDMI terminals.

### PCM

- Outputs PCM format to DIGITAL AUDIO OUT or HDMI terminals.

### Off

- Disables digital audio output.

### Dolby Digital

- Outputs audio to Dolby Digital type if the source supports Dolby digital audio.

## Audio input

- Selects an input way of audio signal.

### Digital

- Selects **Digital** to input audio signal from HDMI terminal.

### Analog

- Selects **Analog** to input audio signal from L/R jack of VIDEO IN INPUT.

### Note:

For HDMI input source only.

## Lock

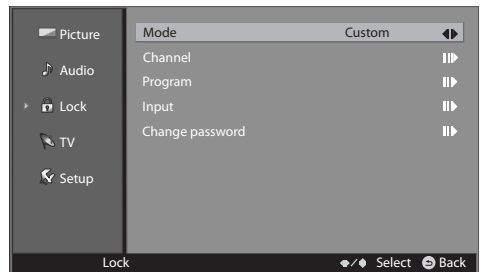
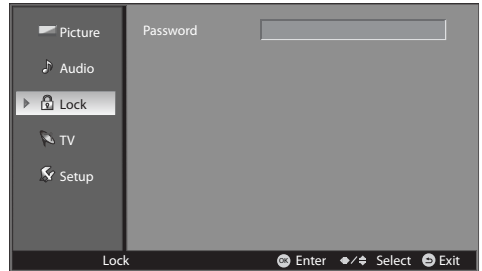

1. Press **MENU** button and **▲▼** buttons to select "Lock", the Lock menu will be displayed.
2. Press **OK** button to enter Lock menu.
3. Press **▲▼** buttons to select item desired.
4. Press **◀▶** buttons to adjust value.
5. Press **⏪** **RETURN** button to return the previous menu.
6. Press **⏹** **EXIT** button to exit menu operation.

## Password

- You need to enter the password when you access locked channel or inputs.
- The default password is 1234.

## Mode

### Custom

- Locks specified inputs.

### Off

- Unlocks all the Lock settings.

### All

- Locks all the inputs.

## Channel

- Prevents children from watching certain channels.
- These channels will be blocked regardless of the program rating.

## Program

### Mode:

- Sets program lock status.

### U.S. TV ratings:

- Sets U.S. TV program ratings.

### U.S. movie ratings:

- Sets U.S. movie ratings.

### Canadian english ratings:

- Sets Canadian english ratings.

### Canadian french ratings:

- Sets Canadian french ratings.

### Dimension:

- If the program is broadcast with RRT5 rating information, the information is downloaded automatically and can be used for parental controls.

| U.S. TV Ratings |                                  |
|-----------------|----------------------------------|
| TV-NR           | None rated                       |
| TV-Y            | All children                     |
| TV-Y7           | Children over seven years of age |
| TV-G            | General audiences                |
| TV-PG           | Parental guidance suggested      |
| TV-14           | Parents strongly cautioned       |
| TV-MA           | Mature audiences only            |

### U.S. Movie Ratings (MPAA)

|       |   |
|-------|---|
| Off   | Movie not rated                                   |
| G     | General audiences                                 |
| PG    | Parental guidance suggested                       |
| PG-13 | Suitable for children 13 and older                |
| R     | Parental guidance suggested for children under 17 |
| NC-17 | Not suitable for children under 17                |
| X     | Adults only                                       |

### Canadian English ratings (C.E.L.R)

|     |                           |
|-----|---------------------------|
| Off | Exempt programming        |
| C   | Children                  |
| C8+ | Children over 8 years old |
| G   | General audiences         |
| PG  | Parental guidance         |
| 14+ | Over 14 years old         |
| 18+ | Adult programming         |

### Canadian French ratings (C.F.L.R)

|         |                    |
|---------|--------------------|
| Off     | Exempt programming |
| G       | General audiences  |
| 8 ans+  | Over 8 years old   |
| 13 ans+ | Over 13 years old  |
| 16 ans+ | Over 16 years old  |
| 18 ans+ | Adult programming  |

## Caution

- The V-Chip system that is used in this set is capable of blocking "NR" programs (non rated, not applicable and none) as per FCC Rules Section 15.120(e)(2). If the option of blocking "NR" programs is chosen "unexpected and possibly confusing results may occur, and you may not receive emergency bulletins or any of the following types of programming:"
  - Emergency Bulletins (Such as EAS messages, weather warnings and others)
  - Locally originated programming / News / Political / Public Service Announcements / Religious / Sports / Weather

## Input

- To disable the specific external input signals.

## Change password

- Changes your parental block password.

## TV

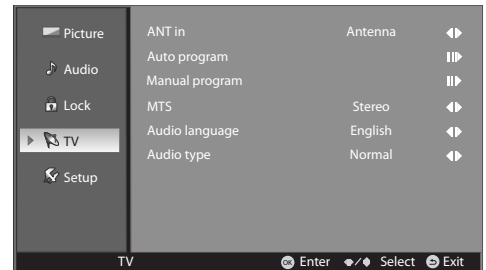

1. Press **MENU** button and **▲▼** buttons to select "TV", the Setup menu will be displayed.
2. Press **OK** button to enter TV menu
3. Press **▲▼** buttons to select item desired.
4. Press **◀▶** buttons to adjust value.
5. Press **⏪ RETURN** button to return the previous menu.
6. Press **⏹ EXIT** button to exit menu operation.

## ANT in

- Selects TV input signal from the **Antenna** or **Cable**.

## Auto program

- Automatically searches and adds available channels to the memory.

## Manual program

- Prevents certain programs from being viewed, the selected channel will be skipped.



## MTS

- Selects the audio mode.
- For analog channels only.

### Stereo:

- Select this option for programs broadcast in stereo.

### SAP:

- Select this option to listen to a secondary audio program, if available.

### Mono:

- Select this option if there is noise or static on weak stereo broadcasts.

## Audio language

- Selects the audio language. (English/Español/Français)

## Audio type

### Normal:

- Sets regular audio only.

### Hearing Impaired:

- Sets the mix of hearing impaired audio with regular audio.

### Visually Impaired:

- Sets the mix of visually impaired audio with regular audio.

### Note:

For Digital channels only.

## Setup

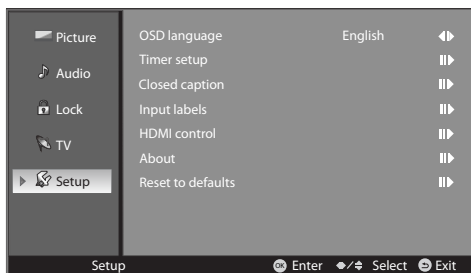

1. Press **MENU** button and **▲▼** buttons to select "Setup", the Setup menu will be displayed.
2. Press **OK** button to enter Setup menu
3. Press **▲▼** buttons to select item desired.
4. Press **◀▶** buttons to adjust value.
5. Press **↶** **RETURN** button to return the previous menu.
6. Press **⊗** **EXIT** button to exit menu operation.

## OSD language

- Selects the screen menu language. (English/Español/Français)

## Time setup

### Sleep Timer:

- Sets a time to switch the TV to standby mode.

### No signal for 10 minutes:

- Switches the TV off automatically when there is no signal received for 10 minutes.

### No activity for 3 hours:

- Switches the TV off automatically when there is no operation for 3 hours.

## Closed caption

- The TV includes a built-in decoder that is capable of providing a text display of the audio.
- The program being viewed must be transmitting the Closed caption (CC) information.

### Analog closed caption:

- Chooses the Closed caption service of Analog broadcasting.

### Digital closed caption:

- Chooses the way for viewing digital captioning.

### Digital caption style:

- Sets display settings in digital program.
  - **Caption style:** Selects **Custom** to sets the styles for your preferred.
  - **Font size:** Selects the font size.
  - **Font style:** Selects the font style.
  - **Font color:** Selects the color for the words.
  - **Font opacity:** Selects the opacity level for the words.
  - **Background color:** Selects the color for the background.
  - **Background opacity:** Selects the opacity level for the background.
  - **Window color:** Selects the color for the window display.
  - **Window opacity:** Selects the opacity level for the window display.

## Input labels

- Selects the terminal and label of the external equipment.
- Devices connected to external input terminals can be labeled for easier identification during the input selection.

## HDMI control

- Allows you to control HDMI compliant devices which are connected through HDMI to your TV.

### Control function:

- Sets to On to active HDMI Control function.

### Power off link:

- Only available when Control function is set to On.
- Sets to Yes to turn off HDMI compliant devices when TV goes to standby mode or shut down.

## About

- Displays TV version and software license.

## Reset to defaults

- Enters initial setup settings.

## Media Player

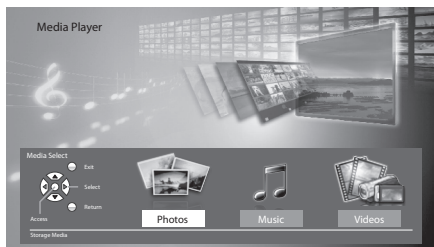

1. Inserts the USB storage device to the USB port on the TV.
2. Press **USB** button to enter Multi-media content.

### Note:

- Partition: FAT32, Not support NTFS format.  
(FAT32—Max Partition Size: 32GB, Max File Size: 4GB)

## Photos

- Browsing Photos

| Buttons | Description                        |
|---------|------------------------------------|
| Red     | • Play slideshow.                  |
| Green   | • Selects viewing type.            |
| Blue    | • Opens option menu.               |
| Yellow  | • Selects Photos, Music, or Videos |
| ▲/▼/◀/▶ | • Selects photos.                  |

- Playing Slideshow

| Buttons | Description          |
|---------|----------------------|
| Blue    | • Opens option menu. |

## Music

| Buttons | Description                         |
|---------|-------------------------------------|
| Blue    | • Opens option menu.                |
| Yellow  | • Selects Photos, Music, or Videos. |
| ▲/▼/◀/▶ | • Selects musics.                   |

## Videos

| Buttons | Description                         |
|---------|-------------------------------------|
| Blue    | • Opens option menu.                |
| Yellow  | • Selects Photos, Music, or Videos. |
| ▲/▼/◀/▶ | • Selects videos.                   |

## Option List

- In multi-media menu, you can press Blue color key to select one of following options.

### Viewing photos

- Transition effect
- Photo size
- Display interval
- Repeat

### Playing music

- Repeat

### Playing movies

- Repeat

## TROUBLESHOOTING

Before calling your dealer or service center for assistance, check the matters below once again.

1. Make sure you have connected LCD TV to your equipment.
2. Check cable connection. Verify that all external equipment and power cords are properly connected.
3. Verify that all power is switched on.
4. If LCD TV still does not produce an image, re-start the external equipment.
5. If the image still does not appear, unplug LCD TV from the external equipment and check the external equipment. The problem may be with your graphics controller rather than with LCD TV. (When you reconnect LCD TV, remember to turn the external equipment and TV off before you power up LCD TV. Power the equipment back on in order of LCD TV and external equipment.)
6. If the problem still exists, check the following chart.

| Problem                      | Try these Solutions  |
|------------------------------|--|
| NO POWER                     | <ul style="list-style-type: none"> <li>● Plug this LCD TV into the AC outlet.</li> <li>● Press POWER button on side control or on Remote Control to turn on LCD TV.</li> <li>● Check POWER Indicator. If this indicator no light, this TV has getting trouble.</li> </ul>  |
| Remote Control does not work | <ul style="list-style-type: none"> <li>● Check the batteries.</li> <li>● Make sure nothing is between the Remote Receiver and the Remote Control.</li> <li>● Make sure you are not too far from LCD TV when using Remote Control.</li> <li>● Maximum operating range is (7m and a 30 degree angle of the front of the TV).</li> <li>● Is direct sunlight or strong artificial light shining on LCD TV's Infrared Remote Receiver? Eliminate the light by closing curtains, pointing the light in a different direction, etc.</li> <li>● A dedicated remote control is required for this model. Basically, the remote control of other brands (including Panasonic other models) cannot be used.</li> </ul> |

| Problem  | Try these Solutions   |
|--|---|
| No image   | <ul style="list-style-type: none"> <li>● Check the connection between the external equipment and LCD TV.</li> <li>● When turning LCD TV on, it takes a few seconds to display the image.</li> <li>● Check the system that you select is corresponding with the external equipment or the video equipment.</li> <li>● Make sure the temperature is not out of the Operating Temperature 32 °F - 95 °F (0 °C - 35 °C).</li> <li>● Turn off power, then turn on again, re-start LCD TV.</li> </ul>   |
| No sound   | <ul style="list-style-type: none"> <li>● Check Audio cable connection from Audio input source.</li> <li>● Adjust the Sound System.</li> <li>● Press VOLUME (+) button.</li> <li>● Press MUTE button.</li> </ul>   |
| There are tiny black points and/ or bright point on the TV | <ul style="list-style-type: none"> <li>● Dark or bright points of light (red, green, or blue) may appear on the screen. This is a characteristic of the LCD panel, not a malfunction of the LCD TV.</li> <li>● LCD panel is produced with very high accuracy technology. There is 99.99% or more dot pixel, but there is also 0.01 % or less of dot pixel lack or dot pixel that is constantly lighted. This is not defect.</li> <li>● Regarding LCD panel characteristic, it may occur picture remain (look like a mirror) when the screen is changed if it displays same screen for a long time. Changing the picture or turn-off the power supply may recover.</li> <li>● Stripe pattern (more, interference stripes) may show up on the screen depends on the reflected picture.</li> </ul> |
| Abnormal color of image                                    | <ul style="list-style-type: none"> <li>● Adjust the value of color.</li> </ul>  |

### Warning

High voltages are used to operate this LCD TV. Do not attempt to open the cabinet.

If the problem still persists after following all operating instructions, contact the sales dealer where you purchased LCD TV or the service center. Give the model number and explain the difficulty. We will advise you how to obtain service.

## SPECIFICATIONS

|  |                            | TC-L24X5/TC-L24X5X   |  |
|--|----------------------------|--|--|
| <b>Power Source</b>                                  |                            | AC 110-127 V, 60Hz   |  |
| <b>Rated Power Consumption</b>                       |                            | 35 W   |  |
| <b>Standby Power Consumption</b>                     |                            | 0.5 W  |  |
| <b>Dimensions (W × H × D)</b>                        |                            | <b>With stand:</b><br>22.3 in. × 16 in × 6.7 in (567 mm × 406 mm × 170 mm)<br><b>Without stand (TV only):</b><br>22.3 in. × 14.4 in × 1.8 in (567 mm × 367 mm × 46 mm) |  |
| <b>Mass</b>  |                            | <b>With stand:</b> 9.9 lb. (4.5 kg)<br><b>Without stand (TV only):</b> 8.8 lb. (4.0 kg)  |  |
| <b>Display panel</b>                                 | <b>Aspect Ratio</b>        | 16:9   |  |
|  | <b>Visible screen size</b> | 521.3 mm (H) × 293.2 mm (V)<br>23.5 inches (diagonal)  |  |
|  | <b>Number of pixels</b>    | 2,073,600 (1,920 (W) × 1,080 (H))  |  |
| <b>Sound</b>   | <b>Speaker</b>             | (100 mm × 27 mm × 27 mm) × 2, 16 Ω   |  |
|  | <b>Audio Output</b>        | 6 W (3 W + 3 W), 10% THD   |  |
| <b>PC Signals</b>                                    |                            | VGA, SVGA, XGA, WXGA, SXGA<br>Horizontal scanning frequency: 31-69 kHz<br>Vertical scanning frequency: 59-86 Hz  |  |
| <b>Tuner</b>   |                            | Digital: ATSC/QAM<br>Analog: NTSC  |  |
| <b>Channel Capability-ATSC/NTSC (Digital/Analog)</b> |                            | VHF/UHF: 2-69, CATV: 1-135   |  |
| <b>Operating Conditions</b>                          |                            | <b>Temperature :</b> 32 °F - 95 °F (0 °C - 35 °C)<br><b>Humidity :</b> 20 % - 80 % RH (non-condensing)   |  |
| <b>Connection Terminals</b>                          | HDMI                       | TYPE A Connector   |  |
|  | VIDEO IN                   | Component  | Y: RCA PIN Type × 1 1.0 V[p-p] (75 Ω)<br>PB, PR: RCA PIN Type × 2 ±0.35 V [p-p] (75 Ω) |
|  |                            | Composite  | VIDEO: RCA PIN Type × 1 1.0 V[p-p] (75 Ω)<br>*Shared with Component-Y                  |
|  |                            | AUDIO L - R  | RCA PIN Type × 2 0.5 V [rms]<br>*Shared audio (component and composite)                |
|  | AUDIO IN                   | Ø 3.5mm jack 0.5V [rms]  |  |
|  | DIGITAL AUDIO OUT          | PCM / Dolby Digital, Coaxial   |  |
|  | PC                         | D-SUB 15PIN: R,G,B / 0.7 V [p-p] (75 Ω)<br>HD, VD / 1.0 - 5.0 V [p-p] (high impedance)   |  |
|  | USB                        | USB 2.0 Type A connector (DC5V MAX500mA)   |  |

## Input Signal Compatibility Chart

### COMPONENT (Y, PB, PR), HDMI

| Signal name              | COMPONENT | HDMI |
|--------------------------|-----------|------|
| 525 (480) / 60i, 60p     | ○         | ○    |
| 750 (720) / 60p          | ○         | ○    |
| 1,125 (1,080) / 60i      | ○         | ○    |
| 1,125 (1,080) / 60p, 24p |           | ○    |

○ Mark : Applicable input signal

### PC (from D-sub terminal/ HDMI terminal)

| Signal name                | Horizontal frequency (kHz) | Vertical frequency (Hz) |
|----------------------------|----------------------------|-------------------------|
| 640 × 400 @70 Hz           | 31.47                      | 70.08                   |
| 640 × 480 @60 Hz           | 31.47                      | 59.94                   |
| 640 × 480 @75 Hz           | 37.50                      | 75.00                   |
| 800 × 600 @60 Hz           | 37.88                      | 60.32                   |
| 800 × 600 @75 Hz           | 46.88                      | 75.00                   |
| 800 × 600 @85 Hz           | 53.67                      | 85.08                   |
| 1,024 × 768 @60 Hz         | 48.36                      | 60.00                   |
| 1,024 × 768 @70 Hz         | 56.48                      | 70.07                   |
| 1,024 × 768 @75 Hz         | 60.02                      | 75.03                   |
| 1,024 × 768 @85 Hz         | 68.68                      | 85.00                   |
| 1,280 × 768 @60 Hz         | 47.78                      | 59.87                   |
| 1,280 × 1,024 @60 Hz       | 63.98                      | 60.02                   |
| 1,366 × 768 @60 Hz         | 48.39                      | 60.04                   |
| Macintosh13" (640 × 480)   | 35.00                      | 66.67                   |
| Macintosh16" (832 × 624)   | 49.73                      | 74.55                   |
| Macintosh21" (1,152 × 870) | 68.68                      | 75.06                   |

Applicable input signal for PC is basically compatible to VESA standard timing

Applicable input signal for PC is basically compatible to HDMI standard timing

**Note:**

- Signals other than above may not be displayed properly.
- The above signals are reformatted for optimal viewing on your display.
- Computer signals which can be input are those with a horizontal scanning frequency of 15 to 110 kHz and vertical scanning frequency of 48 to 120 Hz. (However, the image will not be displayed properly if the signals exceed 1,200 lines.)

## Multi-media Supported Specification

### Photos

| Format | File extension | Image resolution (pixel)  | Details / Restrictions   |
|--------|----------------|---|--|
| JPEG   | .jpeg          | Baseline jpeg:<br>4x4 to 17000 x 10000<br>Progressive jpeg:<br>4x4 to 4000 x 4000 | DCF*1 and EXIF*2 standards<br>Sub-sampling : 4:4:4, 4:2:2, 4:2:0 |

\*1 : Design rule for Camera File system - unified standard established by Japan Electronics and Information Technology Industries Association (JEITA)

\*2 : Exchangeable Image File - image file format used by digital cameras

### Music

| Codec | File extension | Restrictions |
|-------|----------------|--------------|
| MP3   | .mp3           | -            |

### Videos

| Container | File extension | Video codec   | Audio codec                             |
|-----------|----------------|---------------|---|
| TS        | .ts<br>.tp     | MPEG 2        | Dolby Digital, MP3                      |
| PS        | .mpg<br>.mpeg  | MPEG 1/MPEG 2 | Dolby Digital, MPEG1 Layer1/2, DVD LPCM |

#### Note:

- Some files may not be played back even if they fulfill these conditions.
- Do not use two-byte characters or other special codes for data.
- The card may become unusable with this TV if the file or folder names are changed.

## LICENSE

This product incorporates the following software or technology:

- (1) the software based in part on the work of the Independent JPEG Group,
- (2) the software developed by the FreeType Project.

### Dolby



- Manufactured under license from Dolby Laboratories. Dolby and the double-D symbol are trademarks of Dolby Laboratories.

### HDMI



- HDMI, the HDMI logo, and High-Definition Multimedia Interface are trademarks or registered trademarks of HDMI Licensing LLC in United States and other countries.

### Energy Star



- Products that have earned the ENERGY STAR® are designed to protect the environment through superior energy efficiency.
- Please keep the factory default settings as shipped, in which the product can meet Energy Star requirements.

### HD TV



- The "HD TV" Logo is a trademark of DIGITALEUROPE.

# Limited Warranty (for U.S.A. and Puerto Rico only)

Panasonic Consumer Marketing Company of North America,  
 Division of Panasonic Corporation of North America  
 One Panasonic Way  
 Secaucus, New Jersey 07094

## Panasonic LCD Television Limited Warranty

### Limited Warranty Coverage

If your product does not work properly because of a defect in materials or workmanship, Panasonic Consumer Marketing Company of North America (referred to as "the warrantor") will, for the length of the period indicated on the chart below, which starts with the date of original purchase ("Limited Warranty period"), at its option either (a) repair your product with new or refurbished parts, (b) replace it with a new or a refurbished equivalent value product, or (c) refund your purchase price. The decision to repair, replace or refund will be made by the warrantor.

| LCD TV CATEGORIES                              | PARTS            | LABOR          | SERVICE  |
|--|------------------|----------------|----------|
| Up to 42" (diagonal)                           | 1 (ONE) YEAR     | 1 (ONE) YEAR   | Carry-In |
| 46" (diagonal) and larger                      |                  |                | On-Site  |
| 3D Eyewear<br>(Passive - non battery operated) | 90 (NINETY) Days | Not Applicable | Mail In  |

During the "Labor" Limited Warranty period there will be no charge for labor. During the "Parts" Limited Warranty period, there will be no charge for parts.

You must carry-in your product or arrange for on-site service during the Limited Warranty period. If non-rechargeable batteries are included, they are not warranted. This Limited Warranty only applies to products purchased and serviced in the United States or Puerto Rico. This Limited Warranty is extended only to the original purchaser of a new product which was not sold "as is". A purchase receipt or other proof of the original purchase date is required for Limited Warranty service.

### On-Site or Carry-In Service

For On-Site or Carry-In Service in the United States and Puerto Rico call 1-877-95-VIERA (1-877-958-4372).

On-site service where applicable requires clear, complete and easy access to the product by the authorized servicer and does not include removal or re-installation of an installed product. It is possible that certain on-site repairs will not be completed on-site, but will require that the product or parts of the product, at the servicer's discretion be removed for shop diagnosis and/or repair and then returned.

### Mail-In Service

For assistance in the U.S.A. and Puerto Rico in obtaining replacement, please ship the product prepaid to:

Panasonic Exchange Center  
 4900 George McVay Drive  
 Suite B  
 McAllen, TX 78503

panacare@us.panasonic.com

When shipping the unit, carefully pack, include all accessories, and send it prepaid, adequately insured and preferably in the original carton. When shipping Lithium Ion batteries please visit our Web Site at [www.panasonic.com/BatteryHandling](http://www.panasonic.com/BatteryHandling) as Panasonic is committed to providing the most up to date information. Include a letter detailing the complaint, a return address and provide a daytime phone number where you can be reached. A valid registered receipt is required under the Limited Warranty.

### Limited Warranty Limits And Exclusions

This Limited Warranty ONLY COVERS failures due to defects in materials or workmanship, and DOES NOT COVER normal wear and tear or cosmetic damage, nor does it cover markings or retained images on the glass panel resulting from viewing fixed images (including, among other things, non-expanded standard 4:3 pictures on wide screen TVs, or onscreen data in a stationary and fixed location). The Limited Warranty ALSO DOES NOT COVER damages which occurred in shipment, or failures which are caused by products not supplied by the warrantor, or failures which result from accidents, misuse, abuse, neglect, bug infestation, mishandling, misapplication, alteration, faulty installation, set-up adjustments, misadjustment of consumer controls, improper maintenance, power line surge, lightning damage, modification, or commercial use (such as in a hotel, office, restaurant, or other business), rental use of the product, service by anyone other than a Factory Service Center or other Authorized Servicer, or damage that is attributable to acts of God.

**THERE ARE NO EXPRESS WARRANTIES EXCEPT AS LISTED UNDER "LIMITED WARRANTY COVERAGE". THE WARRANTOR IS NOT LIABLE FOR INCIDENTAL OR CONSEQUENTIAL DAMAGES RESULTING FROM THE USE OF THIS PRODUCT, OR ARISING OUT OF ANY BREACH OF THIS LIMITED WARRANTY.** (As examples, this excludes damages for lost time, cost of having someone remove or re-install an installed unit if applicable, or travel to and from the servicer. The items listed are not exclusive, but are for illustration only.) **ALL EXPRESS AND IMPLIED WARRANTIES, INCLUDING THE LIMITED WARRANTY OF MERCHANTABILITY, ARE LIMITED TO THE PERIOD OF THE LIMITED WARRANTY.**

Some states do not allow the exclusion or limitation of incidental or consequential damages, or limitations on how long an implied Limited Warranty lasts, so the exclusions may not apply to you.

This Limited Warranty gives you specific legal rights and you may also have others rights which vary from state to state. If a problem with this product develops during or after the Limited Warranty period, you may contact your dealer or Service Center. If the problem is not handled to your satisfaction, then write to the warrantor's Consumer Affairs Department at the addresses listed for the warrantor.

**PARTS AND SERVICE (INCLUDING COST OF AN ON-SITE SERVICE CALL, WHERE APPLICABLE) WHICH ARE NOT COVERED BY THIS LIMITED WARRANTY ARE YOUR RESPONSIBILITY.**



# Customer Services Directory (for U.S.A. and Puerto Rico)

## Customer Services Directory (United States and Puerto Rico)

Obtain Product Information and Operating Assistance; locate your nearest Dealer or Service Center; purchase Parts and Accessories; or make Customer Service and Literature requests by visiting our Web Site at:

<http://www.panasonic.com/help>

or, contact us via the web at:

<http://www.panasonic.com/contactinfo>

You may also contact us directly at:

1-877-95-VIERA (958-4372)

Monday-Friday 9 am-9 pm; Saturday-Sunday 10 am-7 pm, EST.

■ For hearing or speech impaired TTY users, TTY: 1-877-833-8855

## Accessory Purchases (United States and Puerto Rico)

Purchase Parts, Accessories and Instruction Books on line for all Panasonic Products by visiting our Web Site at:

<http://www.pstc.panasonic.com>

or, send your request by E-mail to:

[npcparts@us.panasonic.com](mailto:npcparts@us.panasonic.com)

You may also contact us directly at:

1-800-332-5368 (Phone) 1-800-237-9080 (Fax Only) (Monday - Friday 9 am to 9 pm, EST.)

**Panasonic Consumer Marketing Company of North America - National Parts Center**

20421 84th Avenue South,

Kent, WA 98032

(We Accept Visa, MasterCard, Discover Card, American Express, and Personal Checks)

■ For hearing or speech impaired TTY users, TTY: 1-866-605-1277

# Limited Warranty (for Canada)

**Panasonic Canada Inc.**  
5770 Ambler Drive, Mississauga, Ontario L4W 2T3  
**PANASONIC PRODUCT – LIMITED WARRANTY**

Panasonic Canada Inc. warrants this product to be free from defects in material and workmanship under normal use and for a period as stated below from the date of original purchase agrees to, at its option either (a) repair your product with new or refurbished parts, (b) replace it with a new or a refurbished equivalent value product, or (c) refund your purchase price. The decision to repair, replace or refund will be made by Panasonic Canada Inc.

|                                  |                         |  |
|----------------------------------|-------------------------|--|
| <b>Viera TV (46" &amp; over)</b> | <b>In-home service</b>  | <b>One (1) year, parts (including panel) and labour.</b> |
| <b>Viera TV (under 46")</b>      | <b>Carry-in service</b> | <b>One (1) year, parts (including panel) and labour.</b> |

In-home Service will be carried out only to locations accessible by roads and within 50 km of an authorized Panasonic service facility.

In-home service requires clear, complete and easy access to the product by the Authorized Servicer and does not include removal or re-installation of an installed product. If removal is required to service the product, it will be at the discretion of the Servicer and in no event will Panasonic Canada Inc. or the Servicer be liable for any special, indirect or consequential damages.

This warranty is given only to the original purchaser, or the person for whom it was purchased as a gift, of a Panasonic brand product mentioned above sold by an authorized Panasonic dealer in Canada and purchased and used in Canada, which product was not sold "as is", and which product was delivered to you in new condition in the original packaging.

**IN ORDER TO BE ELIGIBLE TO RECEIVE WARRANTY SERVICE HEREUNDER, A PURCHASE RECEIPT OR OTHER PROOF OF DATE OF ORIGINAL PURCHASE, SHOWING AMOUNT PAID AND PLACE OF PURCHASE IS REQUIRED**

## **LIMITATIONS AND EXCLUSIONS**

This warranty ONLY COVERS failures due to defects in materials or workmanship, and DOES NOT COVER normal wear and tear or cosmetic damage. The warranty ALSO DOES NOT COVER damages which occurred in shipment, or failures which are caused by products not supplied by Panasonic Canada Inc., or failures which result from accidents, misuse, abuse, neglect, mishandling, misapplication, alteration, faulty installation, set-up adjustments, misadjustment of consumer controls, improper maintenance, power line surge, lightning damage, modification, introduction of sand, humidity or liquids, commercial use such as hotel, office, restaurant, or other business or rental use of the product, or service by anyone other than a Authorized Servicer, or damage that is attributable to acts of God. Dry cell batteries are also excluded from coverage under this warranty.

THIS EXPRESS, LIMITED WARRANTY IS IN LIEU OF ALL OTHER WARRANTIES, EXPRESS OR IMPLIED, INCLUDING ANY IMPLIED WARRANTIES OF MERCHANTABILITY AND FITNESS FOR A PARTICULAR PURPOSE. IN NO EVENT WILL PANASONIC CANADA INC. BE LIABLE FOR ANY SPECIAL, INDIRECT OR CONSEQUENTIAL DAMAGES RESULTING FROM THE USE OF THIS PRODUCT OR ARISING OUT OF ANY BREACH OF ANY EXPRESS OR IMPLIED WARRANTY. (As examples, this warranty excludes damages for lost time, travel to and from the Authorized Servicer, loss of or damage to media or images, data or other memory or recorded content. This list of items is not exhaustive, but for illustration only.)

In certain instances, some jurisdictions do not allow the exclusion or limitation of incidental or consequential damages, or the exclusion of implied warranties, so the above limitations and exclusions may not be applicable. This warranty gives you specific legal rights and you may have other rights which vary depending on your province or territory.

## **WARRANTY SERVICE**

**For product operation and information assistance, please contact:**

Our Customer Care Centre: 1-800 #: 1-866-330-0014  
or visit our website: <https://conciierge.panasonic.ca>

**For product repairs, please contact Viera Customer Care Agent using the above contact info.**

### **IF YOU SHIP THE PRODUCT TO A SERVICENTRE**

Carefully pack and send prepaid, adequately insured and preferably in the original carton.  
Include details of the defect claimed, and proof of date of original purchase.

## *Useful Information*

---

---

### ***Customer Service***

#### ***Customer Service Directory***

Obtain products information and operative assistant; localize the closer distributor or Service Center; buy spare parts and accessories by our web site to Latin American:

**<http://www.lar.panasonic.com>**

Also you may contact us directly by our Contact Center:

|                           |  |
|---------------------------|--|
| <b>Panama</b>             | <b>800-PANA (800-7262)</b>   |
| <b>Colombia</b>           | <b>01-8000-94PANA (01-8000-947262)</b>                                       |
| <b>Ecuador</b>            | <b>1800-PANASONIC (1800-726276)</b>  |
| <b>Costa Rica</b>         | <b>800-PANA737 (800-7262737)</b>   |
| <b>El Salvador</b>        | <b>800-PANA (800-7262)</b>   |
| <b>Guatemala</b>          | <b>1-801-811-PANA (1-801-811-7262)</b>                                       |
| <b>Chile</b>              | <b>800-390-602</b><br><b>From a cell phone: 797-5000</b>                     |
| <b>Venezuela</b>          | <b>800-PANA-800 (800-7262-800)</b>   |
| <b>Uruguay</b>            | <b>0-800-PANA (0-800-7262)</b>   |
| <b>Peru</b>               | <b>0-800-00-PAN (0-800-00726)</b>  |
| <b>Argentina</b>          | <b>0800-333-PANA (0800-333-7262)</b><br><b>0810-321-PANA (0810-321-7262)</b> |
| <b>Paraguay</b>           | <b>800-11-PANA (800-11-7262)</b>   |
| <b>Dominican Republic</b> | <b>809-200-8000</b>  |

#### ***Mexico Service***

To obtain information in the Republic of Mexico contact us at:

**[email: atencion.clientes@mx.panasonic.com](mailto:atencion.clientes@mx.panasonic.com)**

Or you may contact us in the next following phones numbers:

**01800-VIP-PANA (01800-847-7262) - Interior**  
**(55) 5000-1200 - Mexico D.F. and Metropolitan Area**

USA Only: Disposal may be regulated in your community due to environmental considerations. For disposal or recycling information, please visit Panasonic website: <http://www.panasonic.com/environmental> or call 1-888-769-0149.

Sólo Estados Unidos: La disposición puede estar regulada en su comunidad debido a consideraciones ambientales. Para información sobre la disposición o reciclaje, por favor visite la página web de Panasonic: <http://www.panasonic.com/environmental> ó llame al 1-888-769-0149.

### Customer's Record

The model number and serial number of this product may be found on its rear panel. You should note this serial number in the space provided below and retain this book, plus your purchase receipt, as a permanent record of your purchase to aid in identification in the event of theft or loss, and for Warranty Service purposes.

**Model Number**

**Serial Number**

---

### Anotación del cliente

El modelo y el número de serie de este producto se encuentran en su panel posterior. Deberá anotarlos en el espacio provisto a continuación y guardar este manual, más el recibo de su compra, como prueba permanente de su adquisición, para que le sirva de ayuda al identificarlo en el caso de que le sea sustraído o lo pierda, y también para disponer de los servicios que le ofrece la garantía.

**Modelo**

**Número de serie**

---